

National Testing Agency

Question Paper Name :	B Tech 8th Apr 2026 Shift 2
Subject Name :	B. Tech
Creation Date :	2026-04-08 18:49:45
Duration :	180
Total Marks :	300
Display Marks:	Yes

B. Tech

Group Number :	1
Group Id :	6911218
Group Maximum Duration :	0
Group Minimum Duration :	180
Show Attended Group? :	No
Edit Attended Group? :	No
Break time :	0
Group Marks :	300

Mathematics Section A

Section Id :	69112143
Section Number :	1
Section type :	Online
Mandatory or Optional :	Mandatory
Number of Questions :	20
Number of Questions to be attempted :	20
Section Marks :	80
Maximum Instruction Time :	0
Sub-Section Number :	1
Sub-Section Id :	69112143
Question Shuffling Allowed :	Yes
Is Section Default? :	No

Question Number : 1 Question Id : 691121526 Question Type : MCQ Option Shuffling : Yes Display Question Number : Yes Is Question Mandatory : No Single Line Question Option : No Option Orientation : Vertical

Consider the relation R on the set $\{-2, -1, 0, 1, 2\}$ defined by $(a, b) \in R$ if and only if $1 + ab > 0$. Then, among the statements :

- I. The number of elements in R is 17
- II. R is an equivalence relation

Options :

6911211786. Only I is true

6911211787. Only II is true

6911211788. Both I and II are true

6911211789. Neither I nor II is true



Question Number : 2 Question Id : 691121527 Question Type : MCQ Option Shuffling : Yes Display Question Number : Yes Is Question Mandatory : No Single Line Question Option : No Option Orientation : Vertical

The number of values of $z \in \mathbb{C}$, satisfying the equations

$$|z - (4 + 8i)| = \sqrt{10} \text{ and } |z - (3 + 5i)| + |z - (5 + 11i)| = 4\sqrt{5}, \text{ is :}$$

Options :

6911211790. 0

6911211791. 2

6911211792. 1

6911211793. 4

Question Number : 3 Question Id : 691121528 Question Type : MCQ Option Shuffling : Yes Display Question Number : Yes Is Question Mandatory : No Single Line Question Option : No Option Orientation : Vertical

If the system of linear equations :

$$x + y + z = 6,$$

$$x + 2y + 5z = 10,$$

$$2x + 3y + \lambda z = \mu$$

has infinitely many solutions, then the value of $\lambda + \mu$ equals :

Options :

6911211794. 12

6911211795. 16

6911211796. 22

6911211797. 28

Question Number : 4 Question Id : 691121529 Question Type : MCQ Option Shuffling : Yes Display Question Number : Yes Is Question Mandatory : No Single Line Question Option : No Option Orientation : Vertical

Let $A = \begin{bmatrix} \alpha & 1 & 2 \\ 2 & 3 & 0 \\ 0 & 4 & 5 \end{bmatrix}$ and $B = \begin{bmatrix} 1 & 0 & 0 \\ 0 & -5\alpha & 0 \\ 0 & 4\alpha & -2\alpha \end{bmatrix} + \text{adj}(A)$. If $\det(B) = 66$, then $\det(\text{adj}(A))$ equals :

Options :

6911211798. 289

6911211799. 361

6911211800. 441

6911211801. 529

Question Number : 5 Question Id : 691121530 Question Type : MCQ Option Shuffling : Yes Display Question Number : Yes Is Question Mandatory : No Single Line Question Option : No Option Orientation : Vertical

Let $\alpha = 3 + 4 + 8 + 9 + 13 + 14 + \dots$ upto 40 terms. If $(\tan\beta)^{\frac{\alpha}{1020}}$ is a root of the equation $x^2 + x - 2 = 0$, $\beta \in \left(0, \frac{\pi}{2}\right)$, then $\sin^2\beta + 3\cos^2\beta$ is equal to :

Options :

6911211802. 2

6911211803. $\frac{7}{4}$

6911211804. $\frac{5}{2}$

6911211805. $\frac{3}{2}$

Question Number : 6 Question Id : 691121531 Question Type : MCQ Option Shuffling : Yes Display Question Number : Yes Is Question Mandatory : No Single Line Question Option : No Option Orientation : Vertical

A candidate has to go to the examination centre to appear in an examination. The candidate uses only one means of transportation for the entire distance out of bus, scooter and car. The probabilities of the candidate going by bus, scooter and car, respectively, are $\frac{2}{5}$, $\frac{1}{5}$ and $\frac{2}{5}$. The probabilities that the candidate reaches late at the examination centre are $\frac{1}{5}$, $\frac{1}{3}$ and $\frac{1}{4}$ if the candidate uses bus, scooter and car, respectively. Given that the candidate reached late at the examination centre, the probability that the candidate travelled by bus is :

Options :

6911211806. $\frac{11}{37}$

6911211807. $\frac{12}{37}$

6911211808. $\frac{13}{37}$

6911211809. $\frac{14}{37}$

Question Number : 7 Question Id : 691121532 Question Type : MCQ Option Shuffling : Yes Display Question Number : Yes Is Question Mandatory : No Single Line Question Option : No Option Orientation : Vertical

A set of four observations has mean 1 and variance 13. Another set of six observations has mean 2 and variance 1. Then, the variance of all these 10 observations is equal to :

Options :

6911211810. 5.96

6911211811. 6.14

6911211812. 6.04

6911211813. 6.24

Question Number : 8 Question Id : 691121533 Question Type : MCQ Option Shuffling : Yes Display Question Number : Yes Is Question Mandatory : No Single Line Question Option : No Option Orientation : Vertical

If $26 \left(\frac{2^3}{3} ({}^{12}C_2) + \frac{2^5}{5} ({}^{12}C_4) + \frac{2^7}{7} ({}^{12}C_6) + \dots + \frac{2^{13}}{13} ({}^{12}C_{12}) \right) = 3^{13} - \alpha$, then α is equal to :

Options :

6911211814. 45

6911211815. 48

6911211816. 51

6911211817. 54

Question Number : 9 Question Id : 691121534 Question Type : MCQ Option Shuffling : Yes Display Question Number : Yes Is Question Mandatory : No Single Line Question Option : No Option Orientation : Vertical

A person has three different bags and four different books. The number of ways, in which he can put these books in the bags so that no bag is empty, is :

Options :

6911211818. 18

6911211819. 36

6911211820. 39

6911211821. 72

Question Number : 10 Question Id : 691121535 Question Type : MCQ Option Shuffling : Yes Display Question Number : Yes Is Question Mandatory : No Single Line Question Option : No Option Orientation : Vertical

If a straight line drawn through the point of intersection of the lines $4x + 3y - 1 = 0$ and $3x + 4y - 1 = 0$, meets the co-ordinate axes at the points P and Q, then the locus of the mid point of PQ is :

Options :

6911211822. $x + y - 7 = 0$

6911211823. $x + y - 14xy = 0$

6911211824. $2x + y + 14xy = 0$

6911211825. $x + 2y - 14xy = 0$

Question Number : 11 Question Id : 691121536 Question Type : MCQ Option Shuffling : Yes Display Question Number : Yes Is Question Mandatory : No Single Line Question Option : No Option Orientation : Vertical

Let O be the vertex of the parabola $y^2 = 4x$ and its chords OP and OQ are perpendicular to each other. If the locus of the mid-point of the line segment PQ is a conic C, then the length of its latus rectum is :

Options :

6911211826. 1

6911211827. 2

6911211828. 4

6911211829. 8

Question Number : 12 Question Id : 691121537 Question Type : MCQ Option Shuffling : Yes Display Question Number : Yes Is Question Mandatory : No Single Line Question Option : No Option Orientation : Vertical

Let $\alpha = 3 \sin^{-1}\left(\frac{6}{11}\right)$ and $\beta = 3 \cos^{-1}\left(\frac{4}{9}\right)$, where inverse trigonometric functions take only the principal values.

Given below are two statements :

Statement I : $\cos(\alpha + \beta) > 0$.

Statement II : $\cos(\alpha) < 0$.

In the light of the above statements, choose the **correct** answer from the options given below :

Options :

6911211830. Both **Statement I** and **Statement II** are true

6911211831. Both **Statement I** and **Statement II** are false

6911211832. **Statement I** is true but **Statement II** is false

6911211833. **Statement I** is false but **Statement II** is true

Question Number : 13 Question Id : 691121538 Question Type : MCQ Option Shuffling : Yes Display Question Number : Yes Is Question Mandatory : No Single Line Question Option : No Option Orientation : Vertical

For the function $f(x) = e^{\sin|x|} - |x|$, $x \in \mathbf{R}$, consider the following statements :

Statement I : f is differentiable for all $x \in \mathbf{R}$.

Statement II : f is increasing in $\left(-\pi, -\frac{\pi}{2}\right)$.

In the light of the above statements, choose the correct answer from the options given below :

Options :

6911211834. Both **Statement I** and **Statement II** are true

6911211835. Both **Statement I** and **Statement II** are false

6911211836. **Statement I** is true but **Statement II** is false

6911211837. **Statement I** is false but **Statement II** is true

Question Number : 14 Question Id : 691121539 Question Type : MCQ Option Shuffling : Yes Display Question Number : Yes Is Question Mandatory : No Single Line Question Option : No Option Orientation : Vertical

Let $\vec{a} = 4\hat{i} - \hat{j} + 3\hat{k}$, $\vec{b} = 10\hat{i} + 2\hat{j} - \hat{k}$ and a vector \vec{c} be such that $2(\vec{a} \times \vec{b}) + 3(\vec{b} \times \vec{c}) = \vec{0}$.

If $\vec{a} \cdot \vec{c} = 15$, then $\vec{c} \cdot (\hat{i} + \hat{j} - 3\hat{k})$ is equal to :

Options :

6911211838. -6

6911211839. -5

6911211840. -4

6911211841. -3

Question Number : 15 Question Id : 691121540 Question Type : MCQ Option Shuffling : Yes Display Question Number : Yes Is Question Mandatory : No Single Line Question Option : No Option Orientation : Vertical

Let the foot of perpendicular from the point $(\lambda, 2, 3)$ on the line $\frac{x-4}{1} = \frac{y-9}{2} = \frac{z-5}{1}$ be the

point $(1, \mu, 2)$. Then the distance between the lines $\frac{x-1}{2} = \frac{y-2}{3} = \frac{z+4}{6}$ and

$\frac{x-\lambda}{2} = \frac{y-\mu}{3} = \frac{z+5}{6}$ is equal to :

Options :

6911211842. $\frac{12}{7}$

6911211843. $\frac{\sqrt{145}}{7}$

6911211844. $\frac{\sqrt{146}}{7}$

6911211845. $\frac{\sqrt{143}}{7}$

Question Number : 16 Question Id : 691121541 Question Type : MCQ Option Shuffling : Yes Display Question Number : Yes Is Question Mandatory : No Single Line Question Option : No Option Orientation : Vertical

The value of the integral $\int_0^2 \frac{\sqrt{x(x^2 + x + 1)}}{(\sqrt{x+1})(\sqrt{x^4 + x^2 + 1})} dx$ is equal to :

Options :

6911211846. $\frac{1}{3} \log_e (3 - 2\sqrt{2})$

6911211847. $\frac{2}{3} \log_e (4 + \sqrt{2})$

6911211848. $\frac{2}{3} \log_e (3 + 2\sqrt{2})$

6911211849. $\frac{1}{3} \log_e (1 + 6\sqrt{2})$

Question Number : 17 Question Id : 691121542 Question Type : MCQ Option Shuffling : Yes Display Question Number : Yes Is Question Mandatory : No Single Line Question Option : No Option Orientation : Vertical

Let $y = y(x)$ be the solution of the differential equation

$x\sqrt{1-x^2} dy + (y\sqrt{1-x^2} - x\cos^{-1}x)dx = 0, x \in (0, 1), \lim_{x \rightarrow 1^-} y(x) = 1$. Then $y\left(\frac{1}{2}\right)$ equals :

Options :

6911211850. $3 - \frac{\pi}{\sqrt{3}}$

6911211851. $4 - \sqrt{3} \pi$



6911211852. $4 - \frac{2\pi}{\sqrt{3}}$

6911211853. $3 - \frac{\pi}{2\sqrt{3}}$

Question Number : 18 Question Id : 691121543 Question Type : MCQ Option Shuffling : Yes Display Question Number : Yes Is Question Mandatory : No Single Line Question Option : No Option Orientation : Vertical

Let $f: (1, \infty) \rightarrow \mathbb{R}$ be a function defined as $f(x) = \frac{x-1}{x+1}$. Let $f^{i+1}(x) = f(f^i(x))$, $i=1, 2, \dots, 25$,

where $f^1(x) = f(x)$. If $g(x) + f^{26}(x) = 0$, $x \in (1, \infty)$, then the area of the region bounded by the curves $y = g(x)$, $2y = 2x - 3$, $y = 0$ and $x = 4$ is :

Options :

6911211854. $\frac{1}{8} + \log_e 2$

6911211855. $\frac{1}{4} + \log_e 2$

6911211856. $\frac{5}{6} + 3 \log_e 2$

6911211857. $\frac{5}{6} + \log_e 2$

Question Number : 19 Question Id : 691121544 Question Type : MCQ Option Shuffling : Yes Display Question Number : Yes Is Question Mandatory : No Single Line Question Option : No Option Orientation : Vertical

Let $f(x) = \begin{cases} \frac{1}{3} & , x \leq \pi/2 \\ \frac{b(1 - \sin x)}{(\pi - 2x)^2} & , x > \pi/2 \end{cases}$. If f is continuous at $x = \pi/2$, then the value of

$\int_0^{3b-6} |x^2 + 2x - 3| dx$ is :

Options :

6911211858. 5

6911211859. 2

6911211860. 3

6911211861. 4

Question Number : 20 Question Id : 691121545 Question Type : MCQ Option Shuffling : Yes Display Question Number : Yes Is Question Mandatory : No Single Line Question Option : No Option Orientation : Vertical

Let $\frac{x^2}{f(a^2 + 7a + 3)} + \frac{y^2}{f(3a + 15)} = 1$ represent an ellipse with major axis along y -axis, where f is

a strictly decreasing positive function on \mathbf{R} . If the set of all possible values of a is $\mathbf{R} - [\alpha, \beta]$, then $\alpha^2 + \beta^2$ is equal to :

Options :

6911211862. 28

6911211863. 40

6911211864. 61

6911211865. 24

Mathematics Section B

Section Id :	69112144
Section Number :	2
Section type :	Online
Mandatory or Optional :	Mandatory
Number of Questions :	5
Number of Questions to be attempted :	5
Section Marks :	20
Maximum Instruction Time :	0
Sub-Section Number :	1
Sub-Section Id :	69112144
Question Shuffling Allowed :	Yes
Is Section Default? :	No

Question Number : 21 Question Id : 691121546 Question Type : SA Display Question Number : Yes Keyboard Layout : Inscript

The sum of squares of all the real solutions of the equation

$$\log_{(x+1)}(2x^2 + 5x + 3) = 4 - \log_{(2x+3)}(x^2 + 2x + 1) \text{ is equal to } \underline{\hspace{2cm}}.$$

Response Type : Numeric

Evaluation Required For SA : Yes

Show Word Count : Yes

Answers Type : Equal

Text Areas : PlainText

Possible Answers :

1

Question Number : 22 Question Id : 691121547 Question Type : SA Display Question Number : Yes Keyboard Layout : Inscript

If $\int_{\frac{\pi}{6}}^{\frac{\pi}{4}} \left(\cot\left(x - \frac{\pi}{3}\right) \cot\left(x + \frac{\pi}{3}\right) + 1 \right) dx = \alpha \log_e(\sqrt{3}-1)$, then $9\alpha^2$ is equal to _____.

Response Type : Numeric

Evaluation Required For SA : Yes

Show Word Count : Yes

Answers Type : Equal

Text Areas : PlainText

Possible Answers :

1

Question Number : 23 Question Id : 691121548 Question Type : SA Display Question Number : Yes Keyboard Layout : Inscript

Let a line L_1 pass through the origin and be perpendicular to the lines

$$L_2: \vec{r} = (3 + t)\hat{i} + (2t - 1)\hat{j} + (2t + 4)\hat{k} \text{ and}$$

$$L_3: \vec{r} = (3 + 2s)\hat{i} + (3 + 2s)\hat{j} + (2 + s)\hat{k}, t, s \in \mathbf{R}.$$

If (a, b, c) , $a \in \mathbf{Z}$, is the point on L_3 at a distance of $\sqrt{17}$ from the point of intersection of L_1 and L_2 , then $(a + b + c)^2$ is equal to _____.

Response Type : Numeric

Evaluation Required For SA : Yes

Show Word Count : Yes

Answers Type : Equal

Text Areas : PlainText

Possible Answers :

1

Question Number : 24 Question Id : 691121549 Question Type : SA Display Question Number : Yes Keyboard Layout : Inscript

Consider the circle $C: x^2 + y^2 - 6x - 8y - 11 = 0$. Let a variable chord AB of the circle C subtend a right angle at the origin. If the locus of the foot of the perpendicular drawn from the origin on the chord AB is the circle $x^2 + y^2 - \alpha x - \beta y - \gamma = 0$, then $\alpha + \beta + 2\gamma$ is equal to _____.

Response Type : Numeric

Evaluation Required For SA : Yes

Show Word Count : Yes

Answers Type : Equal

Text Areas : PlainText

Possible Answers :

1

Question Number : 25 Question Id : 691121550 Question Type : SA Display Question Number : Yes Keyboard Layout : Inscript

Let f be a polynomial function such that

$$\log_2(f(x)) = \left(\log_2 \left(2 + \frac{2}{3} + \frac{2}{9} + \dots \infty \right) \right) \cdot \log_3 \left(1 + \frac{f(x)}{f(1/x)} \right), x > 0 \text{ and } f(6) = 37. \text{ Then } \sum_{n=1}^{10} f(n) \text{ is}$$

equal to _____.

Response Type : Numeric

Evaluation Required For SA : Yes

Show Word Count : Yes

Answers Type : Equal

Text Areas : PlainText

Possible Answers :

1

Physics Section A

Section Id :

69112145

Section Number :

3

Section type :

Online

Mandatory or Optional :

Mandatory

Number of Questions :	20
Number of Questions to be attempted :	20
Section Marks :	80
Maximum Instruction Time :	0
Sub-Section Number :	1
Sub-Section Id :	69112145
Question Shuffling Allowed :	Yes
Is Section Default? :	No

Question Number : 26 Question Id : 691121551 Question Type : MCQ Option Shuffling : Yes Display Question Number : Yes Is Question Mandatory : No Single Line Question Option : No Option Orientation : Vertical

A new unit (α) of length is chosen such that it is equal to the speed of light in vacuum. What is the distance between Venus and Earth in terms of α units if light takes 6 min. 40 s to cover this distance ?

Options :

6911211871. 200α

6911211872. 400α

6911211873. 300α

6911211874. 500α

Question Number : 27 Question Id : 691121552 Question Type : MCQ Option Shuffling : Yes Display Question Number : Yes Is Question Mandatory : No Single Line Question Option : No Option Orientation : Vertical

Consider the equation
$$H = \frac{x^p \epsilon^q E^r}{t^s}$$

Where H = magnetic field; E = electric field, ϵ = permittivity, x = distance, t = time

The values of p , q , r and s respectively are :

Options :

6911211875. 1, 1, 1, 1

6911211876. -1, 1, 2, 1

6911211877. 1, -1, -2, 1

6911211878. -1, -2, -2, 1

Question Number : 28 Question Id : 691121553 Question Type : MCQ Option Shuffling : Yes Display Question Number : Yes Is Question Mandatory : No Single Line Question Option : No Option Orientation : Vertical

A car moving with a speed of 54 km/h takes a turn of radius 20 m. A simple pendulum is suspended from the ceiling of the car. Determine the angle made by the string of the pendulum with the vertical during the turning. (Take $g = 10 \text{ m/s}^2$)

Options :

6911211879. $\tan^{-1}(0.5)$

6911211880. $\tan^{-1}(0.75)$

6911211881. $\tan^{-1}(1.125)$

6911211882. $\tan^{-1}(0.25)$

Question Number : 29 Question Id : 691121554 Question Type : MCQ Option Shuffling : Yes Display Question Number : Yes Is Question Mandatory : No Single Line Question Option : No Option Orientation : Vertical

A gas balloon is going up with a constant velocity of 10 m/s. When this balloon reached a height of 75 m, a stone is dropped from it and balloon keeps moving up with the same velocity. The height of the balloon when the stone hits the ground is _____ m. (Take $g = 10 \text{ m/s}^2$)

Options :

6911211883. 85

6911211884. 150

6911211885. 129

6911211886. 125

Question Number : 30 Question Id : 691121555 Question Type : MCQ Option Shuffling : Yes Display Question Number : Yes Is Question Mandatory : No Single Line Question Option : No Option Orientation : Vertical

A thin biconvex lens is prepared from the glass ($\mu = 1.5$) both curved surfaces of which have equal radii of 20 cm each. Left side surface of the lens is silvered from outside to make it reflecting. To have the position of image and object at the same place, the object should be placed, from the lens at a distance of _____ cm.

Options :

6911211887. 10

6911211888. 12.5

6911211889. 13

6911211890. 13.5

Question Number : 31 Question Id : 691121556 Question Type : MCQ Option Shuffling : Yes Display Question Number : Yes Is Question Mandatory : No Single Line Question Option : No Option Orientation : Vertical

Two identical bodies, projected with the same speed at two different angles cover the same horizontal range R . If the time of flight of these bodies are 5 s and 10 s, respectively, then the value of R is _____ m. (Take $g = 10 \text{ m/s}^2$)

Options :

6911211891. 250

6911211892. 25

6911211893. 500

6911211894. 125

Question Number : 32 Question Id : 691121557 Question Type : MCQ Option Shuffling : Yes Display Question Number : Yes Is Question Mandatory : No Single Line Question Option : No Option Orientation : Vertical

A solid cylinder having radius R and length L is slipping on a rough horizontal plane. At time $t = 0$ the cylinder has a translational velocity $v_0 = 49 \text{ m/s}$, perpendicular to its axis and a rotational velocity $v_0/4R$ about the centre. The time taken by the cylinder to start rolling is _____ seconds. (coefficient of kinetic friction $\mu_K = 0.25$ and $g = 9.8 \text{ m/s}^2$)

Options :

6911211895. 15

6911211896. 5

6911211897. 10

6911211898. 7.5

Question Number : 33 Question Id : 691121558 Question Type : MCQ Option Shuffling : Yes Display Question Number : Yes Is Question Mandatory : No Single Line Question Option : No Option Orientation : Vertical

A liquid of density 600 kg/m^3 flowing steadily in a tube of varying cross-section. The cross-section at a point A is 1.0 cm^2 and that at B is 20 mm^2 . Both the points A and B are in same horizontal plane, the speed of the liquid at A is 10 cm/s . The difference in pressures at A and B points is _____ Pa.

Options :

6911211899. 18

6911211900. 144

6911211901. 36

6911211902. 72

Question Number : 34 Question Id : 691121559 Question Type : MCQ Option Shuffling : Yes Display Question Number : Yes Is Question Mandatory : No Single Line Question Option : No Option Orientation : Vertical

A spherical liquid drop of radius R acquires the terminal velocity v_1 when falls through a gas of viscosity η . Now the drop is broken into 64 identical droplets and each droplet acquires terminal velocity v_2 falling through the same gas. The ratio of terminal velocities v_1/v_2 is _____.

Options :

6911211903. 4

6911211904. 0.25

6911211905. 32

6911211906. 16

Question Number : 35 Question Id : 691121560 Question Type : MCQ Option Shuffling : Yes Display Question Number : Yes Is Question Mandatory : No Single Line Question Option : No Option Orientation : Vertical

One mole of diatomic gas having rotational modes only is kept in a cylinder with a piston system. The cross-section area of the cylinder is 4 cm^2 . The gas is heated slowly to raise the temperature by 1.2°C during which the piston moves by 25 mm . The amount of heat supplied to the gas is _____ J. (Atmospheric pressure = 100 kPa , $R = 8.3 \text{ J/mol}\cdot\text{K}$) (Neglect mass of the piston)

Options :

6911211907. 24.8

6911211908. 25

6911211909. 15.04

6911211910. 29.98

Question Number : 36 Question Id : 691121561 Question Type : MCQ Option Shuffling : Yes Display Question Number : Yes Is Question Mandatory : No Single Line Question Option : No Option Orientation : Vertical

Initial pressure and volume of a monoatomic ideal gas are P and V . The change in internal energy of this gas in adiabatic expansion to volume $V_{final} = 27 V$ is _____ J.

Options :

6911211911. $-2 PV (3\sqrt{3} - 1)$

6911211912. $\frac{4}{3} PV$

6911211913. $-\frac{4}{3} PV$



6911211914. $\frac{3}{4}PV$

Question Number : 37 Question Id : 691121562 Question Type : MCQ Option Shuffling : Yes Display Question Number : Yes Is Question Mandatory : No Single Line Question Option : No Option Orientation : Vertical

The frequency of oscillation of a mass m suspended by a spring is v_1 . If the length of the spring is cut to half, the same mass oscillates with frequency v_2 . The value of v_2/v_1 is _____.

Options :

6911211915. 1

6911211916. 2

6911211917. $\sqrt{2}$

6911211918. $\sqrt{3}$

Question Number : 38 Question Id : 691121563 Question Type : MCQ Option Shuffling : Yes Display Question Number : Yes Is Question Mandatory : No Single Line Question Option : No Option Orientation : Vertical

A monochromatic source of light operating at 15 kW emits 2.5×10^{22} photons/s. The region of an electromagnetic spectrum to which the emitted electromagnetic radiation belongs to _____.
(Take $h = 6.6 \times 10^{-34}$ J.s and $c = 3 \times 10^8$ m/s).

Options :

6911211919. Microwave

6911211920. Infrared

6911211921. Visible

6911211922. Ultraviolet

Question Number : 39 Question Id : 691121564 Question Type : MCQ Option Shuffling : Yes Display Question Number : Yes Is Question Mandatory : No Single Line Question Option : No Option Orientation : Vertical

A current carrying circular loop of radius 2 cm with unit normal $\hat{n} = \frac{\hat{k} + \hat{i}}{\sqrt{2}}$ is placed in a magnetic field, $\vec{B} = B_0(3\hat{i} + 2\hat{k})$. If $B_0 = 4 \times 10^{-3}$ T and current $I = 100\sqrt{2}$ A, the torque experienced by the loop is _____ Wb.A. ($\pi = 3.14$)

Options :

6911211923. $16 \times 10^{-5} \hat{k}$

6911211924. $5024 \times 10^{-7} \hat{k}$

6911211925. $5024 \times 10^{-7} \hat{i}$

6911211926. $5024 \times 10^{-7} \hat{j}$

Question Number : 40 Question Id : 691121565 Question Type : MCQ Option Shuffling : Yes Display Question Number : Yes Is Question Mandatory : No Single Line Question Option : No Option Orientation : Vertical

A 30 cm long solenoid has 10 turns per cm and area of 5 cm^2 . The current through the solenoid coil varies from 2 A to 4 A in 3.14 s. The e.m.f. induced in the coil is $\alpha \times 10^{-5} \text{ V}$. The value α is _____.

Options :

6911211927. 60

6911211928. 12

6911211929. 120

6911211930. 34

Question Number : 41 Question Id : 691121566 Question Type : MCQ Option Shuffling : Yes Display Question Number : Yes Is Question Mandatory : No Single Line Question Option : No Option Orientation : Vertical

Two point charges $q_1 = 3 \mu\text{C}$ and $q_2 = -4 \mu\text{C}$ are placed at points $(2\hat{i} + 3\hat{j} + 3\hat{k})$ and $(\hat{i} + \hat{j} + \hat{k})$ respectively. Force on charge q_2 is _____ N. $\left(\text{Take } \frac{1}{4\pi\epsilon_0} = 9 \times 10^9 \text{ SI Units} \right)$

Options :

6911211931. $(12\hat{i} + 24\hat{j} + 24\hat{k}) \times 10^{-3}$

6911211932. $(4\hat{i} + 8\hat{j} + 8\hat{k}) \times 10^{-3}$

6911211933. $(3\hat{i} + 6\hat{j} + 6\hat{k}) \times 10^{-3}$

6911211934. $(-4\hat{i} - 8\hat{j} - 8\hat{k}) \times 10^{-3}$

Question Number : 42 Question Id : 691121567 Question Type : MCQ Option Shuffling : Yes Display Question Number : Yes Is Question Mandatory : No Single Line Question Option : No Option Orientation : Vertical

Light ray incident along a vector \vec{AO} ($\vec{AO} = 2\hat{i} - 3\hat{j}$) emerges out along vector \vec{OB} ($\vec{OB} = C\hat{i} - 4\hat{j}$) as shown in the figure below. The value of C is _____.

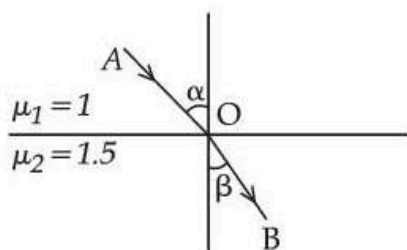

Options :

6911211935. 1.6
 6911211936. 0.16
 6911211937. 11.6
 6911211938. 16

Question Number : 43 Question Id : 691121568 Question Type : MCQ Option Shuffling : Yes Display Question Number : Yes Is Question Mandatory : No Single Line Question Option : No Option Orientation : Vertical

K_1 and K_2 be the maximum kinetic energies of photoelectrons emitted from a surface of a given material for the light of wavelength λ_1 and λ_2 , respectively. If $\lambda_1 = 2\lambda_2$ then the work function of material is given by :

Options :

6911211939. $K_2 + 2K_1$
 6911211940. $2K_2 - K_1$
 6911211941. $K_1 - 2K_2$
 6911211942. $K_2 - 2K_1$

Question Number : 44 Question Id : 691121569 Question Type : MCQ Option Shuffling : Yes Display Question Number : Yes Is Question Mandatory : No Single Line Question Option : No Option Orientation : Vertical

Two radioactive substances A and B of mass numbers 200 and 212 respectively, shows spontaneous α -decay with same Q value of 1 MeV. The ratio of energies of α -rays produced by A and B is _____.

Options :

6911211943. $\frac{2548}{2650}$

6911211944. $\frac{2706}{2646}$

6911211945. $\frac{2597}{2600}$

6911211946. $\frac{2862}{2499}$

Question Number : 45 Question Id : 691121570 Question Type : MCQ Option Shuffling : Yes Display Question Number : Yes Is Question Mandatory : No Single Line Question Option : No Option Orientation : Vertical

The output Y for the given inputs A and B to the circuit is :

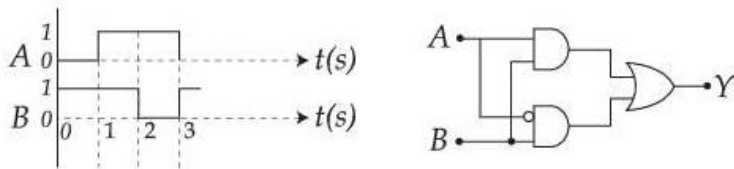

Options :

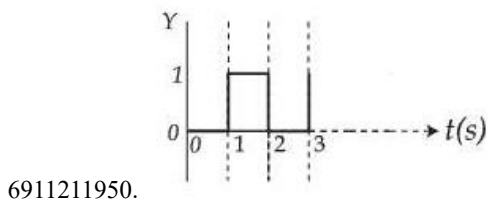
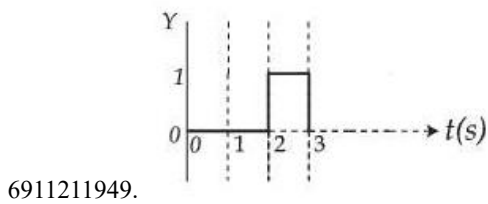
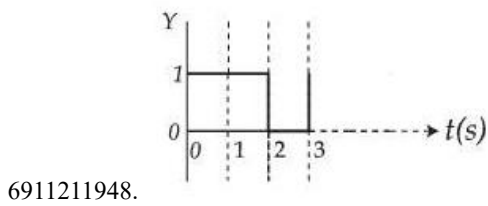
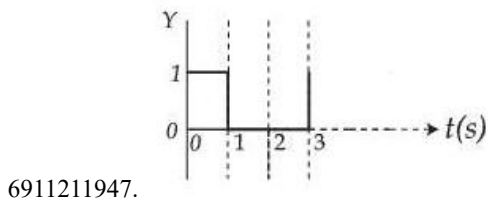

Physics Section B

Section Id :	69112146
Section Number :	4
Section type :	Online
Mandatory or Optional :	Mandatory

Number of Questions :	5
Number of Questions to be attempted :	5
Section Marks :	20
Maximum Instruction Time :	0
Sub-Section Number :	1
Sub-Section Id :	69112146
Question Shuffling Allowed :	Yes
Is Section Default? :	No

Question Number : 46 Question Id : 691121571 Question Type : SA Display Question Number : Yes Keyboard Layout : Inscript

A parallel plate capacitor is having separation between plates 0.885 mm. It has a capacitance of $1 \mu\text{F}$ when the space between the plates is filled with an insulating material of resistivity $1 \times 10^{13} \Omega\text{m}$ and resistance $17.7 \times 10^{14} \Omega$. Relative permittivity of the insulating material is $\alpha \times 10^7$. The value of α is _____.

(Take permittivity of free space = $8.85 \times 10^{-12} \text{ F/m}$)

Response Type : Numeric

Evaluation Required For SA : Yes

Show Word Count : Yes

Answers Type : Equal

Text Areas : PlainText

Possible Answers :

1

Question Number : 47 Question Id : 691121572 Question Type : SA Display Question Number : Yes Keyboard Layout : Inscript

Some distant star is to be observed by some telescope of diameter of objective lens a , at an angular resolution of 3.0×10^{-7} radian. If the wavelength of light from the star reaching the telescope is 500 nm, the minimum diameter of the objective lens of the telescope is _____ cm. (nearest interger)

Response Type : Numeric

Evaluation Required For SA : Yes

Show Word Count : Yes

Answers Type : Equal

Text Areas : PlainText

Possible Answers :

1

Question Number : 48 Question Id : 691121573 Question Type : SA Display Question Number : Yes Keyboard Layout : Inscript

A 5 mg particle carrying a charge of $5\pi \times 10^{-6} \text{ C}$ is moving with velocity of $(3\hat{i} + 2\hat{k}) \times 10^{-2} \text{ m/s}$

in a region having magnetic field $\vec{B} = 0.1 \hat{k} \text{ Wb/m}^2$. It moves a distance of α meter along \hat{k} when it completes 5 revolutions. The value of α is _____.

Response Type : Numeric

Evaluation Required For SA : Yes

Show Word Count : Yes

Answers Type : Equal

Text Areas : PlainText

Possible Answers :

1

Question Number : 49 Question Id : 691121574 Question Type : SA Display Question Number : Yes Keyboard Layout : Inscript

The stored charge in the capacitor in steady state of the following circuit is _____ μC .

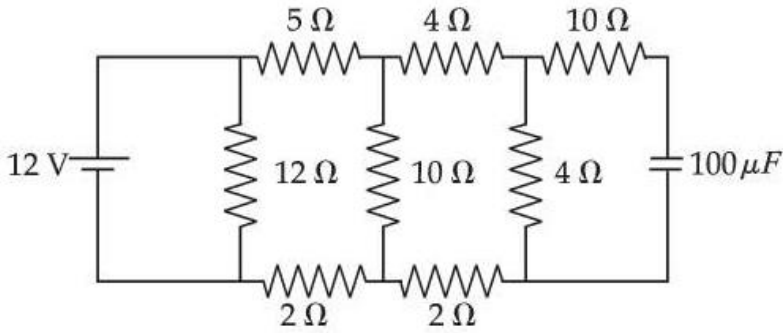

Response Type : Numeric

Evaluation Required For SA : Yes

Show Word Count : Yes

Answers Type : Equal

Text Areas : PlainText

Possible Answers :

1

Question Number : 50 Question Id : 691121575 Question Type : SA Display Question Number : Yes Keyboard Layout : Inscript

Two masses of 3.4 kg and 2.5 kg are accelerated from an initial speed of 5 m/s and 12 m/s, respectively. The distances traversed by the masses in the 5th second are 104 m and 129 m, respectively. The ratio of their momenta after 10 s is $\frac{x}{8}$. The value of x is _____.

Response Type : Numeric

Evaluation Required For SA : Yes

Show Word Count : Yes

Answers Type : Equal

Text Areas : PlainText

Possible Answers :

1

Chemistry Section A

Section Id :	69112147
Section Number :	5
Section type :	Online
Mandatory or Optional :	Mandatory
Number of Questions :	20
Number of Questions to be attempted :	20
Section Marks :	80
Maximum Instruction Time :	0
Sub-Section Number :	1
Sub-Section Id :	69112147
Question Shuffling Allowed :	Yes
Is Section Default? :	No

Question Number : 51 Question Id : 691121576 Question Type : MCQ Option Shuffling : Yes Display Question Number : Yes Is Question Mandatory : No Single Line Question Option : No Option Orientation : Vertical

Match List - I with List - II.

List - I		List - II	
Mass of substance		Number of atoms	
A.	1.8 mg water	I.	$2 \times 10^{-4} \times N_A$
B.	9.8 mg sulphuric acid	II.	$1.5 \times 10^{-4} \times N_A$
C.	1.8 mg carbon	III.	$3 \times 10^{-4} \times N_A$
D.	5.85 mg salt (NaCl)	IV.	$7 \times 10^{-4} \times N_A$

Choose the **correct** answer from the options given below :

Options :

6911211956. A-IV, B-III, C-I, D-II

6911211957. A-III, B-II, C-IV, D-I

6911211958. A-III, B-IV, C-II, D-I

6911211959. A-III, B-IV, C-I, D-II

Question Number : 52 Question Id : 691121577 Question Type : MCQ Option Shuffling : Yes Display Question Number : Yes Is Question Mandatory : No Single Line Question Option : No Option Orientation : Vertical

Given below are two statements :

Given : Molar mass of C, H, O, Cl are 12, 1, 16 and 35.5 g mol⁻¹, respectively

Statement I : In 30% (w/w) solution of methanol in CCl₄(at T K), the mole fraction of CCl₄ is equal to 0.33.

Statement II : Mixture of methanol and CCl₄ shows positive deviation from Raoult's law.

In the light of the above statements, choose the **correct** answer from the options given below :

Options :

6911211960. Both **Statement I** and **Statement II** are true

6911211961. Both **Statement I** and **Statement II** are false

6911211962. **Statement I** is true but **Statement II** is false

6911211963. **Statement I** is false but **Statement II** is true

Question Number : 53 Question Id : 691121578 Question Type : MCQ Option Shuffling : Yes Display Question Number : Yes Is Question Mandatory : No Single Line Question Option : No Option Orientation : Vertical

Bromine trifluoride autoionizes to form BrF₂[⊕] and BrF₄[⊖]. The shapes of the cation and anion are respectively _____, and _____.

Options :

6911211964. bent, square planar

6911211965. linear, square planar

6911211966. bent, see-saw

6911211967. linear, tetrahedral

Question Number : 54 Question Id : 691121579 Question Type : MCQ Option Shuffling : Yes Display Question Number : Yes Is Question Mandatory : No Single Line Question Option : No Option Orientation : Vertical

Which of the following statements are **not correct** ?

- A. For water, magnitude of K_b is more than the magnitude of K_f .
- B. The elevation in boiling point of water when a non-volatile solute is added to it is larger in magnitude than its depression in freezing point.
- C. Osmotic pressure measurement is preferred over any other colligative property to determine molar mass of proteins and polymers.

D. The dimerised form of benzoic acid in benzene is $\text{C}_6\text{H}_5-\overset{\text{O}}{\parallel}{\text{C}}-\text{OH} \cdots \cdots \text{O}=\overset{\text{OH}}{\text{C}}-\text{C}_6\text{H}_5$

Choose the **correct** answer from the options given below :

Options :

6911211968. A and B only

6911211969. A and D only

6911211970. A, B and D only

6911211971. A, C and D only

Question Number : 55 Question Id : 691121580 Question Type : MCQ Option Shuffling : Yes Display Question Number : Yes Is Question Mandatory : No Single Line Question Option : No Option Orientation : Vertical

Consider the following reactions in which all the reactants and products are present in gaseous state

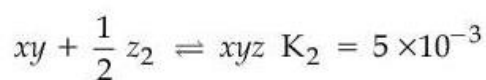
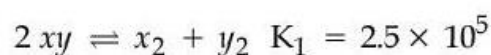

The value of K_3 for the equilibrium $\frac{1}{2}x_2 + \frac{1}{2}y_2 + \frac{1}{2}z_2 \rightleftharpoons xyz$ is :

Options :

6911211972. 2.5×10^{-3}

6911211973. 2.5×10^3

6911211974. 1.0×10^{-5}

6911211975. 5×10^{-3}

Question Number : 56 Question Id : 691121581 Question Type : MCQ Option Shuffling : Yes Display Question Number : Yes Is Question Mandatory : No Single Line Question Option : No Option Orientation : Vertical

Given at 298 K : $E_{\text{Fe}^{2+}/\text{Fe}}^{\ominus} = X \text{ Volt}$

$E_{\text{Fe}^{3+}/\text{Fe}}^{\ominus} = Y \text{ Volt}$

The $E_{\text{Fe}^{3+}/\text{Fe}^{2+}}^{\ominus}$ in Volt at 298 K is given by :

Options :

6911211976. $2X - 3Y$

6911211977. $3Y - 2X$

6911211978. $3Y + 2X$

6911211979. $Y + X$

Question Number : 57 Question Id : 691121582 Question Type : MCQ Option Shuffling : Yes Display Question Number : Yes Is Question Mandatory : No Single Line Question Option : No Option Orientation : Vertical

Given below are two statements :

$R = 8.314 \text{ J K}^{-1} \text{ mol}^{-1}$ and $1 \text{ cal} = 4.2 \text{ J}$

Statement I : When $E_a = 12.6 \text{ kcal/mol}$, the room temperature rate constant is doubled by a 10°C increase in temperature (298 K to 308 K)

Statement II : For a first order reactions $A \rightarrow B$,

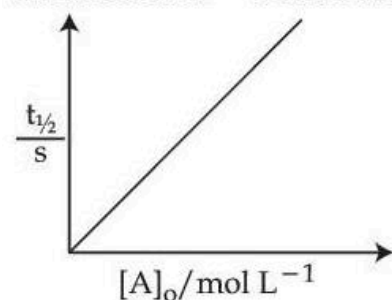

Here $[A]_0$ is the initial concentration of A and $t_{1/2}$ is half life of reaction.

In the light of the above statements, choose the **correct** answer from the options given below :

Options :

6911211980. Both **Statement I** and **Statement II** are true

6911211981. Both **Statement I** and **Statement II** are false

6911211982. **Statement I** is true but **Statement II** is false

6911211983. **Statement I** is false but **Statement II** is true

Question Number : 58 Question Id : 691121583 Question Type : MCQ Option Shuffling : Yes Display Question Number : Yes Is Question Mandatory : No Single Line Question Option : No Option Orientation : Vertical

Match List - I with List - II.

List - I	List - II
Electronic configuration of neutral atom (where $n = 2$)	1 st Ionization Energy (kJ mol^{-1})
A. ns^2	I. 2080
B. ns^2np^1	II. 899
C. ns^2np^3	III. 800
D. ns^2np^6	IV. 1402

Choose the **correct** answer from the options given below :

Options :

6911211984. A-II, B-III, C-IV, D-I

6911211985. A-IV, B-III, C-II, D-I

6911211986. A-III, B-II, C-IV, D-I

6911211987. A-III, B-II, C-I, D-IV

Question Number : 59 Question Id : 691121584 Question Type : MCQ Option Shuffling : Yes Display Question Number : Yes Is Question Mandatory : No Single Line Question Option : No Option Orientation : Vertical

Find the **correct** statements related to group 15 hydrides.

- A. Reducing nature increases from NH_3 to BiH_3
- B. Tendency to donate lone pair of electrons decreases from NH_3 to BiH_3
- C. The stability of hydrides decreases from NH_3 to BiH_3
- D. HEH bond angle decreases from NH_3 to SbH_3 (E = Elements of group 15)

Choose the **correct** answer from the options given below :

Options :

6911211988. A and B only

6911211989. B and C only

6911211990. A, B, C and D

6911211991. A, C and D Only

Question Number : 60 Question Id : 691121585 Question Type : MCQ Option Shuffling : Yes Display Question Number : Yes Is Question Mandatory : No Single Line Question Option : No Option Orientation : Vertical

Given below are two statements :

Statement I : The number of pairs among $[\text{Ti}^{4+}, \text{V}^{2+}]$, $[\text{V}^{2+}, \text{Mn}^{2+}]$, $[\text{Mn}^{2+}, \text{Fe}^{3+}]$ and $[\text{V}^{2+}, \text{Cr}^{2+}]$ in which both ions are coloured is 3.

Statement II : The number of pairs among $[\text{La}^{3+}, \text{Yb}^{2+}]$, $[\text{Lu}^{3+}, \text{Ce}^{4+}]$ and $[\text{Ac}^{3+}, \text{Lr}^{3+}]$ ions in which both are diamagnetic is 3.

In the light of the above statements, choose the **correct** from the options given below :

Options :

6911211992. Both **Statement I** and **Statement II** are correct
6911211993. Both **Statement I** and **Statement II** are incorrect
6911211994. **Statement I** is correct but **Statement II** is incorrect
6911211995. **Statement I** is incorrect but **Statement II** is correct

Question Number : 61 Question Id : 691121586 Question Type : MCQ Option Shuffling : Yes Display Question Number : Yes Is Question Mandatory : No Single Line Question Option : No Option Orientation : Vertical

Given below are two statements for catalytic properties of transition metals.

Statement I : First row transition metals which act as catalyst utilise their 3d electrons only for formation of bonds between reactant molecules and atoms on the surface of catalyst.

Statement II : There is increase in the concentration of reactants on the surface of catalyst which strengthens the bonds in reacting molecules.

In the light of the above statements, choose the **correct** answer from the options given below :

Options :

6911211996. Both **Statement I** and **Statement II** are correct
6911211997. Both **Statement I** and **Statement II** are incorrect
6911211998. **Statement I** is correct but **Statement II** is incorrect
6911211999. **Statement I** is incorrect but **Statement II** is correct

Question Number : 62 Question Id : 691121587 Question Type : MCQ Option Shuffling : Yes Display Question Number : Yes Is Question Mandatory : No Single Line Question Option : No Option Orientation : Vertical

Given below are two statements :

Statement I : Vapours of the liquid with higher boiling point condense before vapours of the liquid with lower boiling points in fractional distillation.

Statement II : The vapours rising up in the fractionating column become richer in high boiling component of the mixture.

In the light of the above statements, choose the **correct** answer from the options given below :

Options :

6911212000. Both **Statement I** and **Statement II** are true

6911212001. Both **Statement I** and **Statement II** are false

6911212002. **Statement I** is true but **Statement II** is false

6911212003. **Statement I** is false but **Statement II** is true

Question Number : 63 Question Id : 691121588 Question Type : MCQ Option Shuffling : Yes Display Question Number : Yes Is Question Mandatory : No Single Line Question Option : No Option Orientation : Vertical

The major product of which of the following reaction is not obtained by rearrangement reaction ?

Options :

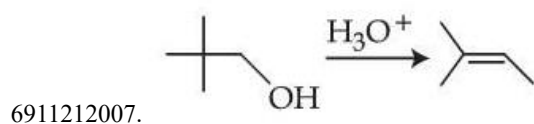
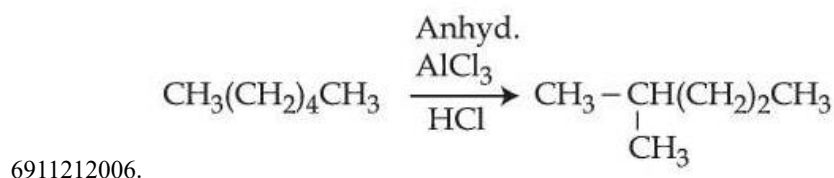
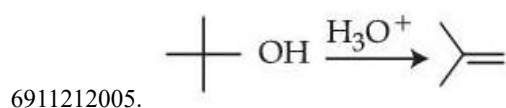
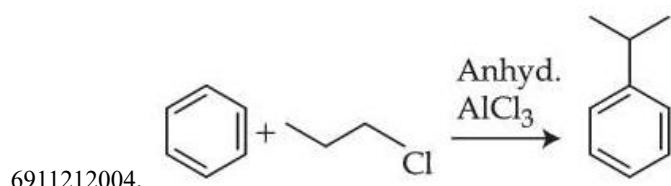

Question Number : 64 Question Id : 691121589 Question Type : MCQ Option Shuffling : Yes Display Question Number : Yes Is Question Mandatory : No Single Line Question Option : No Option Orientation : Vertical

The total number of aromatic compounds/species from the following is

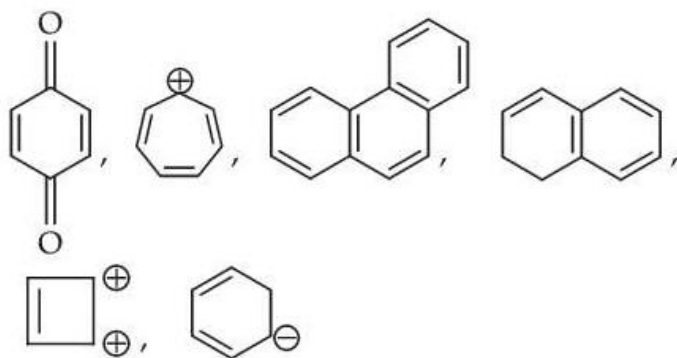

Options :

6911212008. 6

6911212009. 4

6911212010. 3

6911212011. 5

Question Number : 65 Question Id : 691121590 Question Type : MCQ Option Shuffling : Yes Display Question Number : Yes Is Question Mandatory : No Single Line Question Option : No Option Orientation : Vertical

n-Butane on monochlorination under photochemical condition gives an optically active compound "P". "P" on further chlorination gives dichloro compounds.

The number of dichloro compounds obtained (ignore stereoisomers) is :

Options :

6911212012. 3

6911212013. 4

6911212014. 5

6911212015. 6

Question Number : 66 Question Id : 691121591 Question Type : MCQ Option Shuffling : Yes Display Question Number : Yes Is Question Mandatory : No Single Line Question Option : No Option Orientation : Vertical

Given below are two statements :

Statement I : Due to increase in van der Waals forces, the order of boiling points is $\text{CH}_3\text{CH}_2\text{CH}_2\text{I} > \text{CH}_3\text{CH}_2\text{I} > \text{CH}_3\text{I}$.

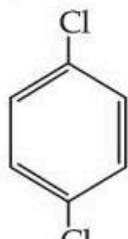
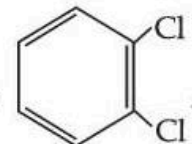
Statement II : As  is more symmetric, its melting point is higher than ,

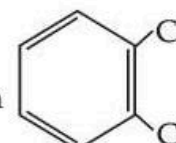
however its boiling point is lower than 

In the light of the above statements, choose the **correct** answer from the options given below :

Options :

6911212016. Both **Statement I** and **Statement II** are true

6911212017. Both **Statement I** and **Statement II** are false

6911212018. **Statement I** is true but **Statement II** is false

6911212019. **Statement I** is false but **Statement II** is true

Question Number : 67 Question Id : 691121592 Question Type : MCQ Option Shuffling : Yes Display Question Number : Yes Is Question Mandatory : No Single Line Question Option : No Option Orientation : Vertical

Consider the following reaction.

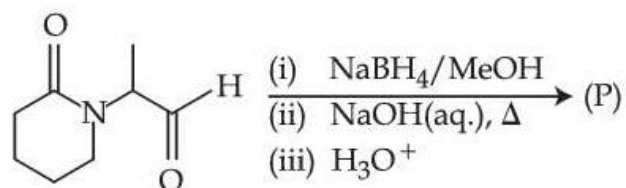

The major product (P) formed is :

Options :

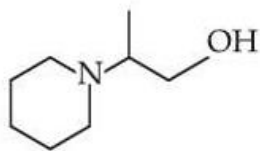

6911212020.

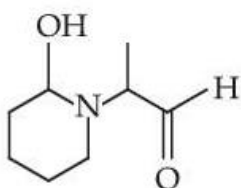

6911212021.

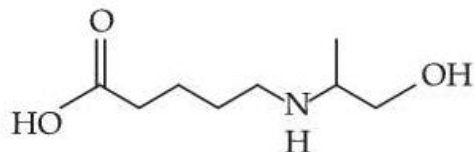

6911212022.

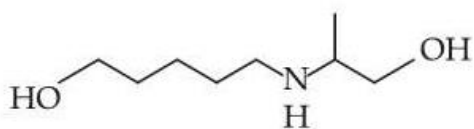

6911212023.

Question Number : 68 Question Id : 691121593 Question Type : MCQ Option Shuffling : Yes Display Question Number : Yes Is Question Mandatory : No Single Line Question Option : No Option Orientation : Vertical

Which statements are True ?

- A. In Hoffmann bromamide degradation, 4 moles of NaOH and 2 moles of Br₂ are consumed per mole of an amide
- B. Hoffmann bromamide reaction is not given by alkyl amides.
- C. Primary amines can be synthesized by Hoffmann bromamide degradation.
- D. Secondary amide on reaction with Br₂ and NaOH will give secondary amine.
- E. The by-products of Hoffmann degradation are Na₂CO₃, NaBr and H₂O.

Choose the **correct** answer from the options given below :

Options :

A, C and E only

6911212024.

B, C and D only

6911212025.



6911212026. C and E only

6911212027. C, D and E only

Question Number : 69 Question Id : 691121594 Question Type : MCQ Option Shuffling : Yes Display Question Number : Yes Is Question Mandatory : No Single Line Question Option : No Option Orientation : Vertical

The **incorrect** statement from the following with respect to carbohydrates is :

Options :

6911212028. All monosaccharides are reducing sugars.

6911212029.

The monosaccharide units obtained from hydrolysis of oligosaccharides are always the same.

6911212030.

Starch and cellulose are typical examples of polysaccharides, which are very high molecular weight compounds of more than ten monosaccharide units.

6911212031.

Open chain and cyclic structures co-exist at equilibrium that are responsible for certain properties as in the case of D – (+) – glucose.

Question Number : 70 Question Id : 691121595 Question Type : MCQ Option Shuffling : Yes Display Question Number : Yes Is Question Mandatory : No Single Line Question Option : No Option Orientation : Vertical

Which of the following amino acid will give violet coloured complex with neutral ferric chloride solution ?

Options :

6911212032. Threonine

6911212033. Serine

6911212034. Tyrosine

6911212035. Cysteine

Chemistry Section B

Section Id :	69112148
Section Number :	6
Section type :	Online
Mandatory or Optional :	Mandatory
Number of Questions :	5
Number of Questions to be attempted :	5
Section Marks :	20
Maximum Instruction Time :	0

Sub-Section Number : 1
Sub-Section Id : 69112148
Question Shuffling Allowed : Yes
Is Section Default? : No

Question Number : 71 Question Id : 691121596 Question Type : SA Display Question Number : Yes Keyboard Layout : Inscript

Number of paramagnetic complexes among the following is _____.

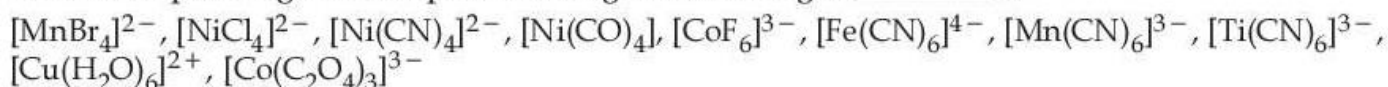

Response Type : Numeric
Evaluation Required For SA : Yes
Show Word Count : Yes
Answers Type : Equal
Text Areas : PlainText
Possible Answers :

1

Question Number : 72 Question Id : 691121597 Question Type : SA Display Question Number : Yes Keyboard Layout : Inscript

'x' is the product which is obtained from benzene by reacting it with carbon monoxide and hydrogen chloride in the presence of cuprous chloride. 'y' is the major product obtained from the benzene by reacting it with ethanoyl chloride in the presence of anhydrous AlCl_3 . Product (major) obtained by heating x and y in the presence of alkali is z. Total number of π (pi) electrons in z is _____.

Response Type : Numeric
Evaluation Required For SA : Yes
Show Word Count : Yes
Answers Type : Equal
Text Areas : PlainText
Possible Answers :

1

Question Number : 73 Question Id : 691121598 Question Type : SA Display Question Number : Yes Keyboard Layout : Inscript

Consider two radiations of wavelengths

1. $\lambda_1 = 2000 \text{ \AA}$
2. $\lambda_2 = 6000 \text{ \AA}$

The ratio of the energies of these two radiations $\left(\frac{E_1}{E_2}\right)$ is _____ (Nearest integer).

Response Type : Numeric
Evaluation Required For SA : Yes
Show Word Count : Yes
Answers Type : Equal
Text Areas : PlainText
Possible Answers :

1

Question Number : 74 Question Id : 691121599 Question Type : SA Display Question Number : Yes Keyboard Layout : Inscript

Consider the reaction

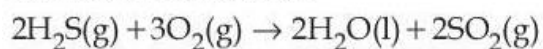

The magnitude of enthalpy change for the reaction in kJ mol^{-1} is _____. (Nearest integer)

Given : $\Delta_f H^\ominus (\text{H}_2\text{S}) = -20.1 \text{ kJ mol}^{-1}$

$$\Delta_f H^\ominus (\text{H}_2\text{O}) = -286.0 \text{ kJ mol}^{-1}$$

$$\Delta_f H^\ominus (\text{SO}_2) = -297.0 \text{ kJ mol}^{-1}$$

Response Type : Numeric

Evaluation Required For SA : Yes

Show Word Count : Yes

Answers Type : Equal

Text Areas : PlainText

Possible Answers :

1

Question Number : 75 **Question Id :** 691121600 **Question Type :** SA Display **Question Number :** Yes **Keyboard Layout :** Inscript

Solid carbon, CaO and CaCO_3 are mixed and allowed to attain equilibrium at T K.

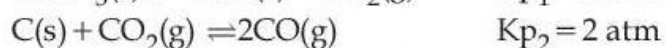
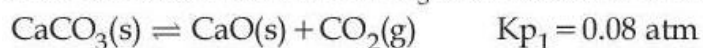

The partial pressure of CO is _____ $\times 10^{-1}$ atm

Response Type : Numeric

Evaluation Required For SA : Yes

Show Word Count : Yes

Answers Type : Equal

Text Areas : PlainText

Possible Answers :

1