

National Testing Agency

Question Paper Name :	B Tech 4th Apr 2026 Shift 1
Subject Name :	B. Tech
Creation Date :	2026-04-04 12:31:20
Duration :	180
Total Marks :	300
Display Marks:	Yes

B. Tech

Group Number :	1
Group Id :	6952784
Group Maximum Duration :	0
Group Minimum Duration :	180
Show Attended Group? :	No
Edit Attended Group? :	No
Break time :	0
Group Marks :	300

Mathematics Section A

Section Id :	69527819
Section Number :	1
Section type :	Online
Mandatory or Optional :	Mandatory
Number of Questions :	20
Number of Questions to be attempted :	20
Section Marks :	80
Maximum Instruction Time :	0
Sub-Section Number :	1
Sub-Section Id :	69527819
Question Shuffling Allowed :	Yes
Is Section Default? :	No

Question Number : 1 Question Id : 695278226 Question Type : MCQ Option Shuffling : Yes Display Question Number : Yes Is Question Mandatory : No Single Line Question Option : No Option Orientation : Vertical

Let $[\cdot]$ denote the greatest integer function. If the domain of the function

$f(x) = \cos^{-1}\left(\frac{4x+2[x]}{3}\right)$ is $[\alpha, \beta]$, then $12(\alpha + \beta)$ is equal to:

Options :

695278766. 6

695278767. 8

695278768. 9

695278769. 4

Question Number : 2 Question Id : 695278227 Question Type : MCQ Option Shuffling : Yes Display Question Number : Yes Is Question Mandatory : No Single Line Question Option : No Option Orientation : Vertical



If the set of all solutions of $|x^2 + x - 9| = |x| + |x^2 - 9|$ is $[\alpha, \beta] \cup [\gamma, \infty)$, then $(\alpha^2 + \beta^2 + \gamma^2)$ is equal to:

Options :

695278770. 9

695278771. 18

695278772. 36

695278773. 72

Question Number : 3 Question Id : 695278228 Question Type : MCQ Option Shuffling : Yes Display Question Number : Yes Is Question Mandatory : No Single Line Question Option : No Option Orientation : Vertical

Let z be a complex number such that $|z + 2| = |z - 2|$ and $\arg\left(\frac{z+3}{z-i}\right) = \frac{\pi}{4}$. Then

$|z|^2$ is equal to:

Options :

695278774. 9

695278775. 4

695278776. 5

695278777. 1

Question Number : 4 Question Id : 695278229 Question Type : MCQ Option Shuffling : Yes Display Question Number : Yes Is Question Mandatory : No Single Line Question Option : No Option Orientation : Vertical

The number of functions $f: \{1, 2, 3, 4\} \rightarrow \{a, b, c\}$, which are not onto, is:

Options :

695278778. 48

695278779. 45

695278780. 51

695278781. 35

Question Number : 5 Question Id : 695278230 Question Type : MCQ Option Shuffling : Yes Display Question Number : Yes Is Question Mandatory : No Single Line Question Option : No Option Orientation : Vertical

Let $S = \left\{ A = \begin{bmatrix} a & b \\ c & d \end{bmatrix} : a, b, c, d \in \{0, 1, 2, 3, 4\} \text{ and } A^2 - 4A + 3I = 0 \right\}$

be a set of 2×2 matrices. Then the number of matrices in S , for which the sum of the diagonal elements is equal to 4, is:

Options :

695278782. 20

695278783. 17

695278784. 21

695278785. 19

Question Number : 6 Question Id : 695278231 Question Type : MCQ Option Shuffling : Yes Display Question Number : Yes Is Question Mandatory : No Single Line Question Option : No Option Orientation : Vertical

Let $A = \begin{bmatrix} 1 & 1 & 2 \\ -2 & 0 & 1 \\ 1 & 3 & 5 \end{bmatrix}$. Then the sum of all elements of the matrix

$adj(adj(2(adjA)^{-1}))$ is equal to:

Options :

695278786. 3

695278787. 4

695278788. -4

695278789. -3

Question Number : 7 Question Id : 695278232 Question Type : MCQ Option Shuffling : Yes Display Question Number : Yes Is Question Mandatory : No Single Line Question Option : No Option Orientation : Vertical

The first term of an A.P. of 30 non-negative terms is $\frac{10}{3}$. If the sum of this A.P. is the cube of its last term, then its common difference is:

Options :

695278790. $\frac{5}{87}$

695278791. $\frac{25}{83}$

695278792. $\frac{15}{29}$

695278793. $\frac{5}{29}$

Question Number : 8 Question Id : 695278233 Question Type : MCQ Option Shuffling : Yes Display Question Number : Yes Is Question Mandatory : No Single Line Question Option : No Option Orientation : Vertical

The number of ways, of forming a queue of 4 boys and 3 girls such that all the girls are not together, is:

Options :

695278794. 5040

695278795. 3050

695278796. 3410

695278797. 4320

Question Number : 9 Question Id : 695278234 Question Type : MCQ Option Shuffling : Yes Display Question Number : Yes Is Question Mandatory : No Single Line Question Option : No Option Orientation : Vertical

Let the smallest value of $k \in \mathbb{N}$, for which the coefficient of x^3 in $(1+x)^3 + (1+x)^4 + (1+x)^5 + \dots + (1+x)^{99} + (1+kx)^{100}$, $x \neq 0$, is $\left(43n + \frac{101}{4}\right) \binom{100}{3}$ for some $n \in \mathbb{N}$, be p . Then the value of $p + n$ is:

Options :

695278798. 10

695278799. 11

695278800. 12

695278801. 13

Question Number : 10 Question Id : 695278235 Question Type : MCQ Option Shuffling : Yes Display Question Number : Yes Is Question Mandatory : No Single Line Question Option : No Option Orientation : Vertical

Suppose that the mean and median of the non-negative numbers 21, 8, 17, a , 51, 103, b , 13, 67, ($a > b$), are 40 and 21, respectively. If the mean deviation about the median is 26, then $2a$ is equal to:

Options :

695278802. 109

695278803. 117

695278804. 161

695278805. 131

Question Number : 11 Question Id : 695278236 Question Type : MCQ Option Shuffling : Yes Display Question Number : Yes Is Question Mandatory : No Single Line Question Option : No Option Orientation : Vertical

Let the line $L_1 : x + 3 = 0$ intersect the lines $L_2 : x - y = 0$ and $L_3 : 3x + y = 0$ at the points A and B, respectively. Let the bisector of the obtuse angle between the lines L_2 and L_3 intersect the line L_1 at the point C. Then $BC^2 : AC^2$ is equal to:

Options :

695278806. 5:1

695278807. 1:5

695278808. 2:3

695278809. 3:2

Question Number : 12 Question Id : 695278237 Question Type : MCQ Option Shuffling : Yes Display Question Number : Yes Is Question Mandatory : No Single Line Question Option : No Option Orientation : Vertical

Let the vertex A of a triangle ABC be (1, 2), and the mid-point of the side AB be (5, -1). If the centroid of this triangle is (3, 4) and its circumcenter is (α , β), then $21(\alpha + \beta)$ is equal to:

Options :

695278810. 309

695278811. 403

695278812. 497

695278813. 524

Question Number : 13 Question Id : 695278238 Question Type : MCQ Option Shuffling : Yes Display Question Number : Yes Is Question Mandatory : No Single Line Question Option : No Option Orientation : Vertical

Suppose that two chords, drawn from the point (1, 2) on the circle $x^2 + y^2 + x - 3y = 0$ are bisected by the y-axis. If the other ends of these chords are R and S, and the mid point of the line segment RS is (α, β) , then $6(\alpha + \beta)$ is equal to:

Options :

695278814. 1

695278815. 3

695278816. 4

695278817. 6

Question Number : 14 Question Id : 695278239 Question Type : MCQ Option Shuffling : Yes Display Question Number : Yes Is Question Mandatory : No Single Line Question Option : No Option Orientation : Vertical

A line with direction ratios 1, -1, 2 intersects the lines $\frac{x}{2} = \frac{y}{3} = \frac{z+1}{3}$ and $\frac{x+1}{-1} = \frac{y-2}{1} = \frac{z}{4}$ at the points P and Q, respectively. If the length of the line segment PQ is α , then $225\alpha^2$ is equal to:

Options :

695278818. 1024

695278819. 1014

695278820. 1104

695278821. 1204

Question Number : 15 Question Id : 695278240 Question Type : MCQ Option Shuffling : Yes Display Question Number : Yes Is Question Mandatory : No Single Line Question Option : No Option Orientation : Vertical

The square of the distance of the point (-2, -8, 6) from the line $\frac{x-1}{1} = \frac{y-1}{2} = \frac{z}{-1}$ along the line $\frac{x+5}{1} = \frac{y+5}{-1} = \frac{z}{2}$ is equal to:

Options :

695278822. 3

695278823. 6

695278824. 8

695278825. 12

Question Number : 16 Question Id : 695278241 Question Type : MCQ Option Shuffling : Yes Display Question Number : Yes Is Question Mandatory : No Single Line Question Option : No Option Orientation : Vertical

If $y = \tan^{-1}\left(\frac{3\cos x - 4\sin x}{4\cos x + 3\sin x}\right) + 2 \tan^{-1}\left(\frac{x}{1 + \sqrt{1-x^2}}\right)$, then $\frac{dy}{dx}$ at $x = \frac{\sqrt{3}}{2}$

is equal to:

Options :

695278826. 3

695278827. -1

695278828. 1

695278829. 2

Question Number : 17 Question Id : 695278242 Question Type : MCQ Option Shuffling : Yes Display Question Number : Yes Is Question Mandatory : No Single Line Question Option : No Option Orientation : Vertical

Let f be a real polynomial of degree n such that $f(x) = f'(x)f''(x)$, for all

$x \in \mathbb{R}$. If $f(0) = 0$, then $36\left(f'(2) + f''(2) + \int_0^2 f(x) dx\right)$ is equal to:

Options :

695278830. 42

695278831. 46

695278832. 56

695278833. 66

Question Number : 18 Question Id : 695278243 Question Type : MCQ Option Shuffling : Yes Display Question Number : Yes Is Question Mandatory : No Single Line Question Option : No Option Orientation : Vertical

The area of the region $\{(x, y): y \leq \pi - |x|, y \leq |x \sin x|, y \geq 0\}$ is:

Options :

695278834. $1 + \frac{\pi^2}{8}$

695278835. $2 + \frac{\pi^2}{4}$

695278836. $\frac{\pi^2}{8} - 1$

695278837. $4 + \frac{\pi^2}{2}$

Question Number : 19 Question Id : 695278244 Question Type : MCQ Option Shuffling : Yes Display Question Number : Yes Is Question Mandatory : No Single Line Question Option : No Option Orientation : Vertical

Let $\int_{-2}^2 (|\sin x| + [x \sin x]) dx = 2(3 - \cos 2) + \beta$, where $[\cdot]$ is the greatest integer

function. Then $\beta \sin\left(\frac{\beta}{2}\right)$ equals:

Options :

695278838. 1

695278839. 2

695278840. 4

695278841. 8

Question Number : 20 Question Id : 695278245 Question Type : MCQ Option Shuffling : Yes Display Question Number : Yes Is Question Mandatory : No Single Line Question Option : No Option Orientation : Vertical

Let $y = y(x)$ be the solution of the differential

equation $\frac{dy}{dx} = (1 + x + x^2)(1 - y + y^2)$, $y(0) = \frac{1}{2}$. Then $(2y(1) - 1)$ is equal to

Options :

695278842. $\sqrt{3} \tan\left(\frac{11\sqrt{3}}{6}\right)$

695278843. $\frac{\sqrt{3}}{2} \tan\left(\frac{11\sqrt{3}}{12}\right)$

695278844. $\sqrt{3} \tan\left(\frac{11\sqrt{3}}{12}\right)$

695278845. $\frac{\sqrt{3}}{2} \tan\left(\frac{11\sqrt{3}}{6}\right)$

Mathematics Section B

Section Id :	69527820
Section Number :	2
Section type :	Online
Mandatory or Optional :	Mandatory
Number of Questions :	5
Number of Questions to be attempted :	5
Section Marks :	20
Maximum Instruction Time :	0
Sub-Section Number :	1
Sub-Section Id :	69527820
Question Shuffling Allowed :	Yes
Is Section Default? :	No

Question Number : 21 Question Id : 695278246 Question Type : SA Display Question Number : Yes Keyboard Layout : Inscript

A coin is tossed 8 times. If the probability that exactly 4 heads appear in the first six tosses and exactly 3 heads appear in the last five tosses is p , then $96p$ is equal to _____.

Response Type : Numeric

Evaluation Required For SA : Yes

Show Word Count : Yes

Answers Type : Equal

Text Areas : PlainText

Possible Answers :

1

Question Number : 22 Question Id : 695278247 Question Type : SA Display Question Number : Yes Keyboard Layout : Inscript

Consider the parabola $P : y^2 = 4kx$ and the ellipse $E : \frac{x^2}{a^2} + \frac{y^2}{b^2} = 1$. Let the line

segment joining the points of intersection of P and E , be their latus rectums. If the eccentricity of E is e , then $e^2 + 2\sqrt{2}$ is equal to _____.

Response Type : Numeric

Evaluation Required For SA : Yes

Show Word Count : Yes

Answers Type : Equal

Text Areas : PlainText

Possible Answers :

1

Question Number : 23 Question Id : 695278248 Question Type : SA Display Question Number : Yes Keyboard Layout : Inscript

If $A = \frac{\sin 3^\circ}{\cos 9^\circ} + \frac{\sin 9^\circ}{\cos 27^\circ} + \frac{\sin 27^\circ}{\cos 81^\circ}$ and $B = \tan 81^\circ - \tan 3^\circ$, then $\frac{B}{A}$ is equal to

_____.

Response Type : Numeric

Evaluation Required For SA : Yes

Show Word Count : Yes

Answers Type : Equal

Text Areas : PlainText

Possible Answers :

1

Question Number : 24 Question Id : 695278249 Question Type : SA Display Question Number : Yes Keyboard Layout : Inscript

Let $\vec{a}_k = (\tan \theta_k) \hat{i} + \hat{j}$ and $\vec{b}_k = \hat{i} - (\cot \theta_k) \hat{j}$, where $\theta_k = \frac{2^{k-1}\pi}{2^n + 1}$, for some

$n \in \mathbb{N}, n > 5$. Then the value of $\frac{\sum_{k=1}^n |\vec{a}_k|^2}{\sum_{k=1}^n |\vec{b}_k|^2}$ is _____.

Response Type : Numeric

Evaluation Required For SA : Yes

Show Word Count : Yes

Answers Type : Equal

Text Areas : PlainText

Possible Answers :

1

Question Number : 25 Question Id : 695278250 Question Type : SA Display Question Number : Yes Keyboard Layout : Inscript

The number of points, at which the function

$f(x) = \max\{6x, 2 + 3x^2\} + |x - 1| \cos\left|x^2 - \frac{1}{4}\right|$, $x \in (-\pi, \pi)$, is not differentiable, is

_____.

Response Type : Numeric

Evaluation Required For SA : Yes

Show Word Count : Yes

Answers Type : Equal

Text Areas : PlainText

Possible Answers :

1

Physics Section A

Section Id :	69527821
Section Number :	3
Section type :	Online
Mandatory or Optional :	Mandatory
Number of Questions :	20
Number of Questions to be attempted :	20
Section Marks :	80
Maximum Instruction Time :	0
Sub-Section Number :	1
Sub-Section Id :	69527821
Question Shuffling Allowed :	Yes
Is Section Default? :	No

Question Number : 26 Question Id : 695278251 Question Type : MCQ Option Shuffling : Yes Display Question Number : Yes Is Question Mandatory : No Single Line Question Option : No Option Orientation : Vertical

In a screw gauge when the circular scale is given five complete rotations it moves linearly by 2.5 mm. If the circular scale has 100 divisions, the least count of screw gauge is _____ mm.

Options :

695278851. 1×10^{-2}

695278852. 1×10^{-3}

695278853. 5×10^{-2}

695278854. 5×10^{-3}

Question Number : 27 Question Id : 695278252 Question Type : MCQ Option Shuffling : Yes Display Question Number : Yes Is Question Mandatory : No Single Line Question Option : No Option Orientation : Vertical

The increase in the pressure required to decrease the volume (ΔV) of water is $6.3 \times 10^7 \text{ N/m}^2$. The percentage decrease in the volume is _____.
(Bulk modulus of water = $2.1 \times 10^9 \text{ N/m}^2$.)

Options :

695278855. 2 %

695278856. 3 %

695278857. 6 %

695278858. 4 %

Question Number : 28 Question Id : 695278253 Question Type : MCQ Option Shuffling : Yes Display Question Number : Yes Is Question Mandatory : No Single Line Question Option : No Option Orientation : Vertical

The time taken by a block of mass m to slide down from the highest point to the lowest point on a rough inclined plane is 50 % more compared to the time taken by the same block on identical inclined smooth plane. Both inclined planes are at 45° with the horizontal. The coefficient of kinetic friction between the rough inclined surface and block is _____.

Options :

695278859. 3/4

695278860. 2/3

695278861. 5/9

695278862. 4/9

Question Number : 29 Question Id : 695278254 Question Type : MCQ Option Shuffling : Yes Display Question Number : Yes Is Question Mandatory : No Single Line Question Option : No Option Orientation : Vertical

Two nuclei of mass number 3 combine with another nucleus of mass number 4 to yield a nucleus of mass number 10. If the binding energy per nucleon for the mass numbers 3, 4 and 10 are 5.6 MeV, 7.4 MeV and 6.1 MeV, respectively, then in the process, $\Delta Mc^2 =$ _____ MeV.

Options :

695278863. 6.9

695278864. 7.9

695278865. 2.2

695278866. 4.3

Question Number : 30 Question Id : 695278255 Question Type : MCQ Option Shuffling : Yes Display Question Number : Yes Is Question Mandatory : No Single Line Question Option : No Option Orientation : Vertical

A solid sphere of mass M and radius R is divided into two unequal parts. The smaller part having mass $M/8$ is converted into a sphere of radius r and the larger part is converted into a circular disc of thickness t and radius $2R$. If I_1 is moment of inertia of a sphere having radius r about an axis through its centre and I_2 is the moment of inertia of a disc about its diameter, the ratio of their moment of inertia $I_2/I_1 =$ _____.

Options :

695278867. 35

695278868. 70

695278869. 140

695278870. 210

Question Number : 31 Question Id : 695278256 Question Type : MCQ Option Shuffling : Yes Display Question Number : Yes Is Question Mandatory : No Single Line Question Option : No Option Orientation : Vertical

The two projectiles are projected with the same initial velocities at the 15° and 30° with respect to the horizontal. The ratio of their ranges is $1:x$. The value of x is

Options :

695278871. $\sqrt{2}$

695278872. $\sqrt{3}$

695278873. $2\sqrt{3}$

695278874. $\frac{1}{\sqrt{2}}$

Question Number : 32 Question Id : 695278257 Question Type : MCQ Option Shuffling : Yes Display Question Number : Yes Is Question Mandatory : No Single Line Question Option : No Option Orientation : Vertical

The graph shows variation of stopping potential V_0 with the frequency ν of the incident radiation for three photosensitive metals X_1 , X_2 and X_3 . Which metal will give out electrons with greater kinetic energy, for the same wavelength of incident radiation?

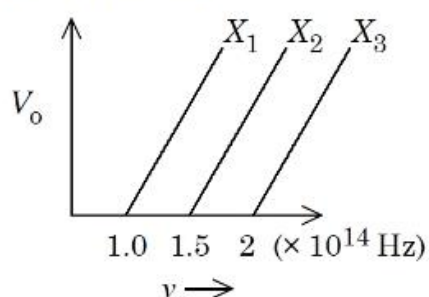

Options :

695278875. X_1

695278876. X_2

695278877. X_3

695278878. All the metals will give out photo electrons with same kinetic energies.

Question Number : 33 Question Id : 695278258 Question Type : MCQ Option Shuffling : Yes Display Question Number : Yes Is Question Mandatory : No Single Line Question Option : No Option Orientation : Vertical

A slit of width a is illuminated by light of wavelength λ . The linear separation between 1st and 3rd minima in the diffraction pattern produced on a screen placed at a distance D from the slit system is _____.

Options :

695278879. $\frac{D\lambda}{a}$

695278880. $1.5 \frac{D\lambda}{a}$

695278881. $2 \frac{D\lambda}{a}$

695278882. $3 \frac{D\lambda}{a}$

Question Number : 34 Question Id : 695278259 Question Type : MCQ Option Shuffling : Yes Display Question Number : Yes Is Question Mandatory : No Single Line Question Option : No Option Orientation : Vertical

A string A of length 0.314 m and Young's modulus 2×10^{10} N/m² is connected to another string B of length and Young's modulus both twice of those of A . This series combination of strings is then suspended from a rigid support and its free end is fixed to a load of mass 0.8 kg. The net change in length of the combination is _____ mm.

(radius of both the strings is 0.2 mm and acceleration due to gravity = 10 m/s²)
(Mass of both strings is to be neglected as compared to the mass of load)

Options :

695278883. 3

695278884. 2

695278885. 1.9

695278886. 1

Question Number : 35 Question Id : 695278260 Question Type : MCQ Option Shuffling : Yes Display Question Number : Yes Is Question Mandatory : No Single Line Question Option : No Option Orientation : Vertical

One gas of n_1 mole of molecules at temperature T_1 , volume V_1 , and pressure P_1 , and another gas of n_2 mole of molecules at temperature T_2 , volume V_2 , and pressure P_2 , are mixed resulting in pressure P and volume V of the mixture. The temperature of the mixture is _____.

Options :

695278887. $(T_1 + T_2)/2$

695278888. $T_1 T_2 PV / (T_2 P_1 V_1 + T_1 P_2 V_2)$

695278889. $(T_2 P_1 V_1 + T_1 P_2 V_2) / (T_1 T_2 PV)$

695278890. $|T_1 - T_2|/2$

Question Number : 36 Question Id : 695278261 Question Type : MCQ Option Shuffling : Yes Display Question Number : Yes Is Question Mandatory : No Single Line Question Option : No Option Orientation : Vertical

An ideal gas undergoes a process maintaining relation between pressure (P) and

volume (V) as $P = P_0 \left(1 + \left(\frac{V_0}{V} \right)^2 \right)^{-1}$, where P_0 and V_0 are constants. If two

samples A and B (two moles each) with initial volumes V_0 and $3V_0$ respectively undergo above mentioned process and attain same pressure, then the difference at the temperatures of these samples, $T_B - T_A$ is _____.

(R = gas constant)

Options :

695278891. $\frac{9P_0V_0}{8R}$

695278892. $\frac{11P_0V_0}{10R}$

695278893. $\frac{7P_0V_0}{6R}$

695278894. $\frac{13P_0V_0}{11R}$

Question Number : 37 Question Id : 695278262 Question Type : MCQ Option Shuffling : Yes Display Question Number : Yes Is Question Mandatory : No Single Line Question Option : No Option Orientation : Vertical

A voltmeter with internal resistance of $x \Omega$ can be used to measure upto 20 V. In order to increase its measuring range to 30 V, the required modification is to _____.

Options :

695278895. connect resistor of $\frac{x}{2} \Omega$, in series with voltmeter.

695278896. connect resistor of $\frac{x}{2} \Omega$, in parallel to voltmeter.

695278897. connect a resistor of $x \Omega$ in series with voltmeter.

695278898. connect resistor of $2x \Omega$ in parallel to voltmeter.

Question Number : 38 Question Id : 695278263 Question Type : MCQ Option Shuffling : Yes Display Question Number : Yes Is Question Mandatory : No Single Line Question Option : No Option Orientation : Vertical

Two 4 bits binary numbers, $A = 1101$ and $B = 1010$ are given in the inputs of a logic circuit shown in figure below. The output (Y) will be :

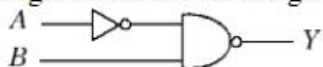

Options :

695278899. $Y = 1101$

695278900. $Y = 0010$

695278901. $Y = 0111$

695278902. $Y = 1000$

Question Number : 39 Question Id : 695278264 Question Type : MCQ Option Shuffling : Yes Display Question Number : Yes Is Question Mandatory : No Single Line Question Option : No Option Orientation : Vertical

A rod of length 10 cm lies along the principle axis of a concave mirror of focal length 10 cm as shown in figure. The length of the image is _____ cm.

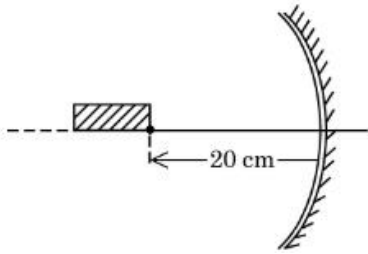

Options :

695278903. 2.5

695278904. 5

695278905. 7.5

695278906. 7

Question Number : 40 Question Id : 695278265 Question Type : MCQ Option Shuffling : Yes Display Question Number : Yes Is Question Mandatory : No Single Line Question Option : No Option Orientation : Vertical

A parallel plate air capacitor is connected to a battery. The plates are pulled apart at uniform speed v . If x is the separation between the plates at any instant, then the time rate of change of electrostatic energy of the capacitor is proportional to x^α , where α is _____.

Options :

695278907. -2

695278908. 1

695278909. -1

695278910. 2

Question Number : 41 Question Id : 695278266 Question Type : MCQ Option Shuffling : Yes Display Question Number : Yes Is Question Mandatory : No Single Line Question Option : No Option Orientation : Vertical

An insulated wire is wound so that it forms a flat coil with $N = 200$ turns. The radius of the innermost turn is $r_1 = 3$ cm, and of the outermost turn $r_2 = 6$ cm. If 20 mA current flows in it then the magnetic moment will be $\alpha \times 10^{-2}$ A.m². The value of α is _____.

Options :

695278911. 4.4

695278912. 2.64

695278913. 3.25

695278914. 1.2

Question Number : 42 Question Id : 695278267 Question Type : MCQ Option Shuffling : Yes Display Question Number : Yes Is Question Mandatory : No Single Line Question Option : No Option Orientation : Vertical

Consider a circuit consisting of a capacitor ($20 \mu\text{F}$), resistor (100Ω) and two identical diodes as shown in figure. The resistance of diode under forward biasing condition is 10Ω . The time constant of the circuit is $\alpha \times 10^{-3}$ s. The value of α is _____

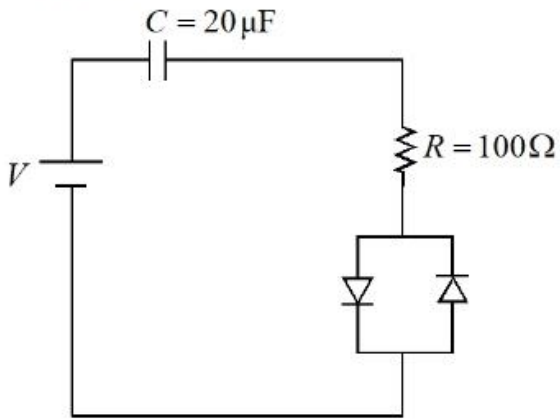

Options :

- 695278915. 2.2
- 695278916. 2.0
- 695278917. 2.1
- 695278918. 2.4

Question Number : 43 Question Id : 695278268 Question Type : MCQ Option Shuffling : Yes Display Question Number : Yes Is Question Mandatory : No Single Line Question Option : No Option Orientation : Vertical

The voltage and the current between A and B points shown in the circuit are _____.

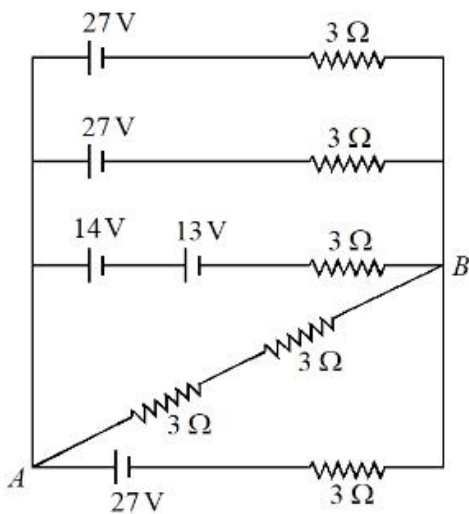

Options :

- 695278919. 24 V, 12 A
- 695278920. 24 V, 4 A
- 695278921. 18 V, 12 A
- 695278922. 27 V, 4 A

Question Number : 44 Question Id : 695278269 Question Type : MCQ Option Shuffling : Yes Display Question Number : Yes Is Question Mandatory : No Single Line Question Option : No Option Orientation : Vertical

A telescope with objective diameter R is used to observe a distant star emitting light of wavelength 500 nm , at a resolution of 5×10^{-7} radian. The value of R is _____ cm.

Options :

695278923. 61

695278924. 122

695278925. 244

695278926. 305

Question Number : 45 Question Id : 695278270 Question Type : MCQ Option Shuffling : Yes Display Question Number : Yes Is Question Mandatory : No Single Line Question Option : No Option Orientation : Vertical

An unpolarized light is incident on the plane interface of air-dielectric medium shown in figure. If the incident angle is equal to Brewster angle, identify the expression representing reflected wave.

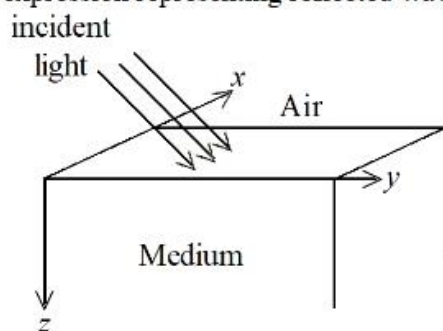

Options :

695278927. $(E_x \hat{i} + E_y \hat{j}) \sin (kx - kz - \omega t)$

695278928. $(E_x \hat{i} + E_z \hat{k}) \sin (kx + ky - \omega t)$

695278929. $(E_x \hat{j} + E_y \hat{k}) \sin (ky + kz - \omega t)$

695278930. $(E_x \hat{i} + E_y \hat{j} + E_z \hat{k}) \sin (kx + ky - kz - \omega t)$

Physics Section B

Section Id :	69527822
Section Number :	4
Section type :	Online
Mandatory or Optional :	Mandatory
Number of Questions :	5
Number of Questions to be attempted :	5
Section Marks :	20
Maximum Instruction Time :	0
Sub-Section Number :	1
Sub-Section Id :	69527822
Question Shuffling Allowed :	Yes
Is Section Default? :	No

Question Number : 46 Question Id : 695278271 Question Type : SA Display Question Number : Yes Keyboard Layout : Inscript

A 1 kg block subjected to two simultaneous forces $(2\hat{i} + 3\hat{j} + 4\hat{k})$ N and $(3\hat{i} - \hat{j} - 2\hat{k})$ N is moved a distance of 25 m along $(3\hat{i} - 4\hat{j})$ direction. The work done in this process is _____ J.

Response Type : Numeric

Evaluation Required For SA : Yes

Show Word Count : Yes

Answers Type : Equal

Text Areas : PlainText

Possible Answers :

1

Question Number : 47 Question Id : 695278272 Question Type : SA Display Question Number : Yes Keyboard Layout : Inscript

The surface tension of a soap solution is 3.5×10^{-2} N/m. The work required to increase the radius of a soap bubble from 1 cm to 2 cm is $\alpha \times 10^{-6}$ J. The value of α is _____.
($\pi = 22/7$)

Response Type : Numeric

Evaluation Required For SA : Yes

Show Word Count : Yes

Answers Type : Equal

Text Areas : PlainText

Possible Answers :

1

Question Number : 48 Question Id : 695278273 Question Type : SA Display Question Number : Yes Keyboard Layout : Inscript

The velocity of a particle executing simple harmonic motion along x -axis is described as $v^2 = 50 - x^2$, where x represents displacement. If the time period of motion is $\frac{x}{7}$ s, the value of x is _____.

Response Type : Numeric

Evaluation Required For SA : Yes

Show Word Count : Yes

Answers Type : Equal

Text Areas : PlainText

Possible Answers :

1

Question Number : 49 Question Id : 695278274 Question Type : SA Display Question Number : Yes Keyboard Layout : Inscript

A body of mass 2 kg begins to move under the influence of time dependent force $\vec{F} = (2t\hat{i} + 6t^2\hat{j})$ N, where \hat{i} and \hat{j} are unit vectors along x and y -axis respectively. The power produced by the force at $t = 2$ s is _____ W.

Response Type : Numeric

Evaluation Required For SA : Yes

Show Word Count : Yes

Answers Type : Equal

Text Areas : PlainText

Possible Answers :

1

Question Number : 50 Question Id : 695278275 Question Type : SA Display Question Number : Yes Keyboard Layout : Inscript

An inductor of 10 mH, capacitor of 0.1 μF and a resistor of 100 Ω are connected in series across an a.c power supply 220 V, 70 Hz. The power factor of the given circuit is 0.5. The difference in the inductive reactance and capacitance reactance is $\sqrt{3} \alpha \Omega$. The value of α is _____.

Response Type : Numeric

Evaluation Required For SA : Yes

Show Word Count : Yes

Answers Type : Equal

Text Areas : PlainText

Possible Answers :

1

Chemistry Section A

Section Id :	69527823
Section Number :	5
Section type :	Online
Mandatory or Optional :	Mandatory
Number of Questions :	20
Number of Questions to be attempted :	20
Section Marks :	80
Maximum Instruction Time :	0
Sub-Section Number :	1
Sub-Section Id :	69527823
Question Shuffling Allowed :	Yes
Is Section Default? :	No

Question Number : 51 Question Id : 695278276 Question Type : MCQ Option Shuffling : Yes Display Question Number : Yes Is Question Mandatory : No Single Line Question Option : No Option Orientation : Vertical

Number of moles and number of molecules in 1.4187 L of SO_2 at STP respectively are

Options :

695278936. 0.1266; 3.812×10^{22}

695278937. 0.0633; 3.812×10^{22}

695278938. 0.1266; 7.6238×10^{22}

695278939. 0.0633; 7.6238×10^{22}

Question Number : 52 Question Id : 695278277 Question Type : MCQ Option Shuffling : Yes Display Question Number : Yes Is Question Mandatory : No Single Line Question Option : No Option Orientation : Vertical

What is the ratio of wave number of first line (lowest energy line) of Balmer series of H atomic spectrum to first line of its Brackett series?

Options :

695278940. 5:1

695278941. 5:0.81

695278942. 5:1.75



695278943. 5:27

Question Number : 53 Question Id : 695278278 Question Type : MCQ Option Shuffling : Yes Display Question Number : Yes Is Question Mandatory : No Single Line Question Option : No Option Orientation : Vertical

Which of the following is correct set of 4 quantum numbers of 19th electron in Chromium (Atomic number = 24) in accordance with Aufbau principle?

Options :

695278944. $n = 3, l = 2, m = +2, s = +\frac{1}{2}$

695278945. $n = 3, l = 2, m = -2, s = +\frac{1}{2}$

695278946. $n = 4, l = 1, m = 0, s = +\frac{1}{2}$

695278947. $n = 4, l = 0, m = 0, s = +\frac{1}{2}$

Question Number : 54 Question Id : 695278279 Question Type : MCQ Option Shuffling : Yes Display Question Number : Yes Is Question Mandatory : No Single Line Question Option : No Option Orientation : Vertical

Given below are two statements:

Statement I: For an ideal gas, heat capacity at constant volume is always greater than the heat capacity at constant pressure.

Statement II: In a constant volume process, no work is produced and all the heat withdrawn goes into the chaotic motion and is reflected by a temperature increase of the ideal gas.

In the light of the above statements, choose the *correct* answer from the options given below

Options :

695278948. Both Statement I and Statement II are true

695278949. Both Statement I and Statement II are false

695278950. Statement I is true but Statement II is false

695278951. Statement I is false but Statement II is true

Question Number : 55 Question Id : 695278280 Question Type : MCQ Option Shuffling : Yes Display Question Number : Yes Is Question Mandatory : No Single Line Question Option : No Option Orientation : Vertical

At T(K), the equilibrium constant of $A_2(g) + B_2(g) \rightleftharpoons C(g)$ is 2.7×10^{-5} . What is the equilibrium constant for $\frac{1}{3}A_2(g) + \frac{1}{3}B_2(g) \rightleftharpoons \frac{1}{3}C(g)$ at the same temperature?

Options :

695278952. $(2.7 \times 10^{-5})^3$

695278953. 6×10^{-2}

695278954. $\sqrt{2.7 \times 10^{-5}}$

695278955. 3×10^{-2}

Question Number : 56 Question Id : 695278281 Question Type : MCQ Option Shuffling : Yes Display Question Number : Yes Is Question Mandatory : No Single Line Question Option : No Option Orientation : Vertical

In order to oxidise a mixture of 1 mole each of FeC_2O_4 , $\text{Fe}_2(\text{C}_2\text{O}_4)_3$, FeSO_4 and $\text{Fe}_2(\text{SO}_4)_3$ in acidic medium, the number of moles of KMnO_4 required is

Options :

695278956. 3

695278957. 2

695278958. 5

695278959. 7

Question Number : 57 Question Id : 695278282 Question Type : MCQ Option Shuffling : Yes Display Question Number : Yes Is Question Mandatory : No Single Line Question Option : No Option Orientation : Vertical

Consider the first order reaction $\text{R} \rightarrow \text{P}$.

The fraction of molecules decomposed in the given first order reaction can be expressed as

Options :

695278960. $1 - e^{k_1 t}$

695278961. $1 + e^{k_1 t}$

695278962. $1 + e^{-k_1 t}$

695278963. $1 - e^{-k_1 t}$

Question Number : 58 Question Id : 695278283 Question Type : MCQ Option Shuffling : Yes Display Question Number : Yes Is Question Mandatory : No Single Line Question Option : No Option Orientation : Vertical

A monoatomic anion (A^-) has 45 neutrons and 36 electrons. Atomic mass, group in the periodic table and physical state at room temperature of the element (A) respectively are

Options :

695278964. 80, 17, liquid

695278965. 81, 16, solid

695278966. 80, 16, gas

695278967. 81, 15, gas

Question Number : 59 Question Id : 695278284 Question Type : MCQ Option Shuffling : Yes Display Question Number : Yes Is Question Mandatory : No Single Line Question Option : No Option Orientation : Vertical

Given below are two statements:

Statement I: The covalency of oxygen is generally two but it can exceed upto four. The oxidation state of oxygen in SO_2 is -2 and in OF_2 it is $+2$.

Statement II: The anomalous behaviour of oxygen when compared to the other elements of group 16 is due to its small size and high electronegativity.

In the light of the above statements, choose the *correct* answer from the options given below

Options :

695278968. Both Statement I and Statement II are true

695278969. Both Statement I and Statement II are false

695278970. Statement I is true but Statement II is false

695278971. Statement I is false but Statement II is true

Question Number : 60 Question Id : 695278285 Question Type : MCQ Option Shuffling : Yes Display Question Number : Yes Is Question Mandatory : No Single Line Question Option : No Option Orientation : Vertical

The **correct** statements among the following are,

- A. Mo(VI) and W(VI) are less stable than Cr(VI).
- B. Ce^{4+} and Tb^{4+} are oxidant while Eu^{2+} and Yb^{2+} are reductant.
- C. Cm and Am have seven unpaired electrons.
- D. Actinoid contraction is greater from element to element than lanthanoid contraction.

Choose the correct answer from the options given below:

Options :

695278972. A and B Only

695278973. C and D Only

695278974. B and D Only

695278975. A and C Only

Question Number : 61 Question Id : 695278286 Question Type : MCQ Option Shuffling : Yes Display Question Number : Yes Is Question Mandatory : No Single Line Question Option : No Option Orientation : Vertical

Correct statements from the following are

- A. Potassium dichromate is an oxidising agent and it oxidises FeSO_4 to $\text{Fe}_2(\text{SO}_4)_3$ in acidic medium.
- B. Sodium dichromate can be used as primary standard in volumetric estimation.
- C. CrO_4^{2-} and $\text{Cr}_2\text{O}_7^{2-}$ are interconvertible in aqueous solution by varying the pH of the solution.
- D. Cr-O-Cr bond angle in $\text{Cr}_2\text{O}_7^{2-}$ is 126° .

Choose the correct answer from the options given below:

Options :

695278976. A, B and C Only

695278977. A, C and D Only

695278978. A and C Only

695278979. B and D Only

Question Number : 62 Question Id : 695278287 Question Type : MCQ Option Shuffling : Yes Display Question Number : Yes Is Question Mandatory : No Single Line Question Option : No Option Orientation : Vertical

Match the LIST-I with LIST-II

List-I Complex ion	List-II Calculated spin only magnetic moment (BM)
A. $[\text{Cr}(\text{H}_2\text{O})_6]^{2+}$	I. 3.87
B. $[\text{Co}(\text{H}_2\text{O})_6]^{2+}$	II. 5.92
C. $[\text{Cu}(\text{H}_2\text{O})_6]^{2+}$	III. 4.90
D. $[\text{Mn}(\text{H}_2\text{O})_6]^{2+}$	IV. 1.73

Choose the *correct* answer from the options given below:

Options :

695278980. A-I, B-III, C-IV, D-II

695278981. A-II, B-I, C-III, D-IV

695278982. A-IV, B-II, C-I, D-III

695278983. A-III, B-I, C-IV, D-II

Question Number : 63 Question Id : 695278288 Question Type : MCQ Option Shuffling : Yes Display Question Number : Yes Is Question Mandatory : No Single Line Question Option : No Option Orientation : Vertical

Increasing order of electron withdrawing power of following functional groups is:

- a. - CN
- b. - COOH
- c. - NO₂
- d. - I

Options :

695278984. $c < b < d < a$

695278985. $c < a < b < d$

695278986. $d < b < a < c$

695278987. $a < b < c < d$

Question Number : 64 Question Id : 695278289 Question Type : MCQ Option Shuffling : Yes Display Question Number : Yes Is Question Mandatory : No Single Line Question Option : No Option Orientation : Vertical

An alkene (X) on ozonolysis followed by reduction gives following products.

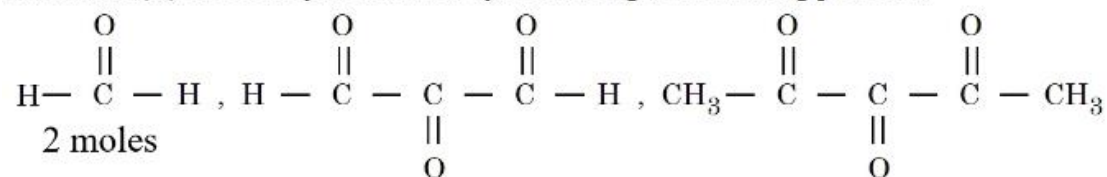

The alkene (X) is:

Options :

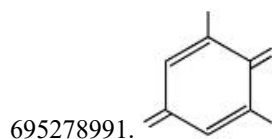
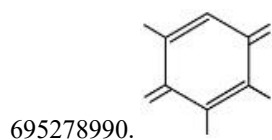
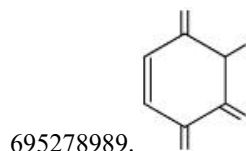
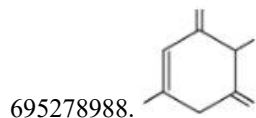

Question Number : 65 Question Id : 695278290 Question Type : MCQ Option Shuffling : Yes Display Question Number : Yes Is Question Mandatory : No Single Line Question Option : No Option Orientation : Vertical

Match the LIST-I with LIST-II

List-I		List-II	
Name of reaction		Reagent or catalyst used	
A.	Finkelstein reaction	I.	SbF ₃
B.	Swarts reaction	II.	Na, dry ether
C.	Sandmeyer's reaction	III.	NaI
D.	Fittig reaction	IV.	Cu ₂ Cl ₂

Choose the *correct* answer from the options given below:

Options :

695278992. A-I, B-IV, C-III, D-II

695278993. A-III, B-I, C-IV, D-II

695278994. A-IV, B-II, C-I, D-III

695278995. A-I, B-III, C-II, D-IV

Question Number : 66 Question Id : 695278291 Question Type : MCQ Option Shuffling : Yes Display Question Number : Yes Is Question Mandatory : No Single Line Question Option : No Option Orientation : Vertical

Amongst the following, the total number of compounds soluble in aqueous NaOH at room temperature is:

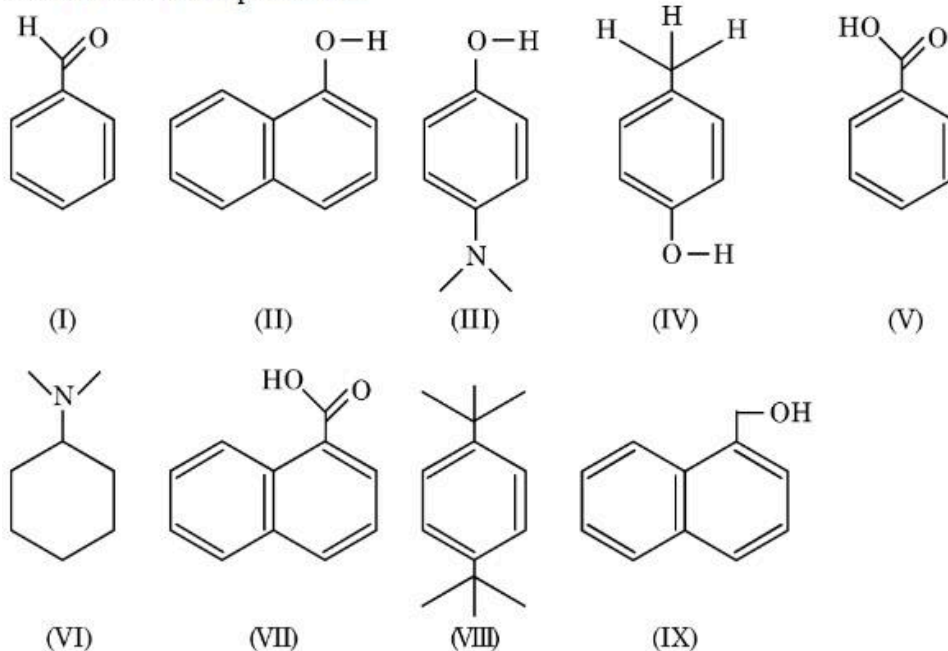

Options :

695278996. 5

695278997. 4

695278998. 6

695278999. 3

Question Number : 67 Question Id : 695278292 Question Type : MCQ Option Shuffling : Yes Display Question Number : Yes Is Question Mandatory : No Single Line Question Option : No Option Orientation : Vertical

Product C of the following reaction sequence will be

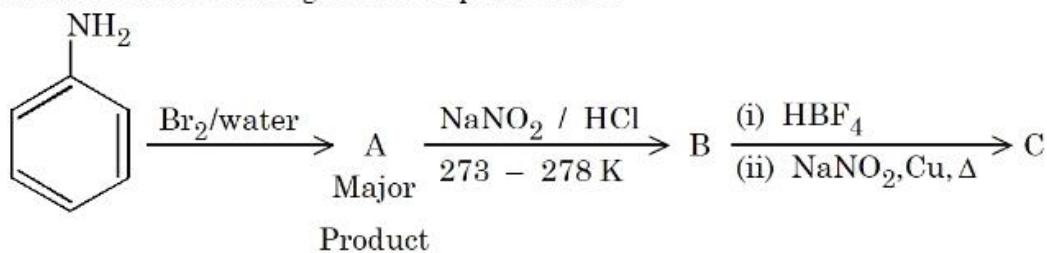

Options :

6952781000. 1-Bromo-4-nitrobenzene

6952781001. 1, 3, 5-Tribromo-2-nitrobenzene

6952781002. 4-Bromo-1-nitrobenzene

6952781003. 1, 3, 5-Tribromobenzene

Question Number : 68 Question Id : 695278293 Question Type : MCQ Option Shuffling : Yes Display Question Number : Yes Is Question Mandatory : No Single Line Question Option : No Option Orientation : Vertical

Given below are two statements:

Statement I: The structure of Maltose is given below:

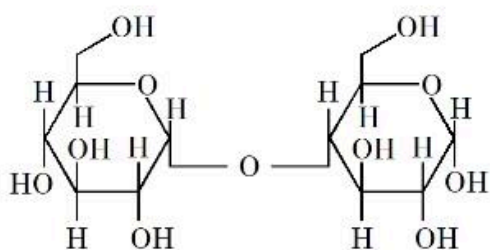

Maltose is a non-reducing

sugar.

Statement II: The structure of Lactose is given below:

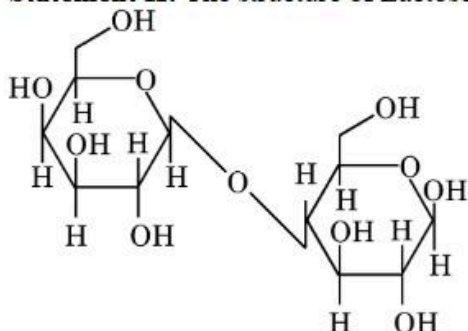

Lactose is a reducing sugar.

In the light of the above statements, choose the **correct** answer from the options given below

Options :

6952781004. Both Statement I and Statement II are true

6952781005. Both Statement I and Statement II are false

6952781006. Statement I is true but Statement II is false

6952781007. Statement I is false but Statement II is true

Question Number : 69 Question Id : 695278294 Question Type : MCQ Option Shuffling : Yes Display Question Number : Yes Is Question Mandatory : No Single Line Question Option : No Option Orientation : Vertical

Match the **LIST-I** with **LIST-II**

List-I		List-II	
Name of amino acid		One letter symbol/type	
A.	Arginine	I.	D/Non-essential
B.	Aspartic acid	II.	R/Essential
C.	Lysine	III.	E/Non-essential
D.	Glutamic acid	IV.	K/Essential

Choose the **correct** answer from the options given below:

Options :

6952781008. A-II, B-I, C-IV, D-III

6952781009. A-IV, B-III, C-II, D-I

6952781010. A-III, B-IV, C-I, D-II

6952781011. A-II, B-IV, C-I, D-III

Question Number : 70 Question Id : 695278295 Question Type : MCQ Option Shuffling : Yes Display Question Number : Yes Is Question Mandatory : No Single Line Question Option : No Option Orientation : Vertical

Identify the colour of compound 'X' in the sequence of the reaction.

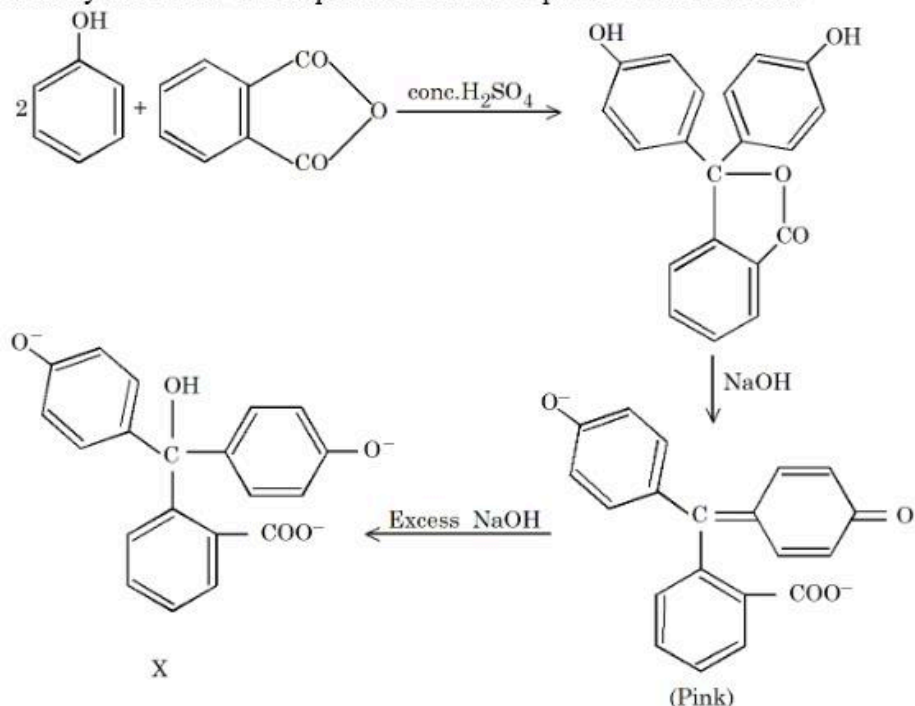

Options :

6952781012. Violet

6952781013. Green

6952781014. Red

6952781015. Colourless

Chemistry Section B

Section Id :	69527824
Section Number :	6
Section type :	Online
Mandatory or Optional :	Mandatory
Number of Questions :	5
Number of Questions to be attempted :	5
Section Marks :	20
Maximum Instruction Time :	0
Sub-Section Number :	1
Sub-Section Id :	69527824
Question Shuffling Allowed :	Yes
Is Section Default? :	No

Question Number : 71 Question Id : 695278296 Question Type : SA Display Question Number : Yes Keyboard Layout : Inscript

According to Lewis theory, the total number of σ bond-pairs and lone pair of electrons around the central atom of XeO_6^{4-} ion is _____.

Response Type : Numeric

Evaluation Required For SA : Yes

Show Word Count : Yes

Answers Type : Equal

Text Areas : PlainText

Possible Answers :

1

Question Number : 72 Question Id : 695278297 Question Type : SA Display Question Number : Yes Keyboard Layout : Inscript

Consider the following sequence of reactions to give the major product (X)

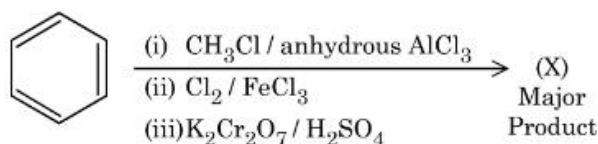

P g of the major product (X) formed is reacted with $NaHCO_3$ solution to liberate a gas which occupied 11.2 dm^3 at STP.

P = _____ g.

(Given molar mass in g mol^{-1} H:1, C:12, O:16, Cl:35.5)

Response Type : Numeric

Evaluation Required For SA : Yes

Show Word Count : Yes

Answers Type : Equal

Text Areas : PlainText

Possible Answers :

1

Question Number : 73 Question Id : 695278298 Question Type : SA Display Question Number : Yes Keyboard Layout : Inscript

2.0 g of a bromo hydrocarbon (X) was subjected to Carius analysis, gave 3.36 g of AgBr. The percentage of carbon in the compound (X) is 26.7%. Total number of carbon atoms in the empirical formula for compound (X) is _____.

(Given molar mass in g mol^{-1} H:1, C:12, Br : 80, Ag : 108)

Response Type : Numeric

Evaluation Required For SA : Yes

Show Word Count : Yes

Answers Type : Equal

Text Areas : PlainText

Possible Answers :

1

Question Number : 74 Question Id : 695278299 Question Type : SA Display Question Number : Yes Keyboard Layout : Inscript

The pH of a solution obtained by mixing 5 mL of 0.1 M NH_4OH solution with 250 mL of 0.1 M NH_4Cl solution is _____ $\times 10^{-2}$. (Nearest integer)

Given: $pK_b (NH_4OH) = 4.74$

$$\log 2 = 0.30$$

$$\log 3 = 0.48$$

$$\log 5 = 0.70$$

Response Type : Numeric

Evaluation Required For SA : Yes

Show Word Count : Yes

Answers Type : Equal

Text Areas : PlainText

Possible Answers :

1

Question Number : 75 Question Id : 695278300 Question Type : SA Display Question Number : Yes Keyboard Layout : Inscript

A non-volatile, non-electrolyte solid solute when dissolved in 40 g of a solvent, the vapour pressure of the solvent decreased from 760 mm Hg to 750 mm Hg. If the same solution boils at 320 K, then the number of moles of the solute present in the solution is _____. (Nearest integer)

[Given: boiling point of the pure solvent = 319.5 K,
 K_b of the solvent = $0.3 \text{ K kg mol}^{-1}$]

Response Type : Numeric

Evaluation Required For SA : Yes

Show Word Count : Yes

Answers Type : Equal

Text Areas : PlainText

Possible Answers :

1

